

# Chemical Analyses of Seawater for Trace Elements

## Recent Progress in Japan on Clean Sampling and Chemical Speciation of Trace Elements

### A Review

Eiichiro NAKAYAMA\*<sup>1</sup>, Yoshimi SUZUKI\*<sup>2</sup>, Kitao FUJIWARA\*<sup>3</sup> and Yasushi KITANO\*<sup>4</sup>

\*<sup>1</sup> *Research Center for Instrumental Analysis, Faculty of Science, Kyoto University, Kyoto 606, Japan*

\*<sup>2</sup> *Geochemical Laboratory, Meteorological Research Institute, Tsukuba, Ibaraki 305, Japan*

\*<sup>3</sup> *Faculty of Integrated Arts and Sciences, Hiroshima University, Hiroshima 730, Japan*

\*<sup>4</sup> *Sugiyama Jogakuen University, Nagoya 464, Japan*

Progress in clean techniques that includes clean sampling, storage, treatment and analysis of seawater samples is essential for the exact determination of trace elements in seawater. Japanese marine chemists have worked vigorously to establish clean techniques and the accumulation of data. Results have met with a measured amount of success, as briefly shown in this review paper. The behavior and distribution of trace elements in seawater are dependent on multifaceted chemical, physical and biological processes occurring in the ocean. Thus, the chemical speciation of inorganic and organic species of trace elements in seawater has been eagerly studied. Specifically, the dissolved states of oxyacid elements such as Cr, I, Se, Te, As and Sb have been determined by using various procedures and methods developed by Japanese marine chemists. The present paper reviews the procedures of chemical speciation for inorganic species of Cr, I, Mn, Mo, W, Se, Te, As and Sb as well as those for organic species of Cr, Ge, I, Se, Hg, Fe and Cu in seawater. The difficulty in obtaining exact measurements of the total concentrations of trace elements in seawater is shown concerning Fe, Cu, Zn and Se as examples.

**Keywords** Trace element, seawater, clean sampling, chemical speciation, inorganic species, metal organic species

1	Introduction	129	3·5	Selenium and tellurium	
2	Clean Sampling: Challenge to the Determination of ng Level Trace Elements	130	3·6	Arsenic and antimony	
3	Inorganic Species of Trace Elements in Seawater	131	4	Organic Species of Trace Elements in Seawater	136
3·1	Chromium		4·1	Chromium, germanium and iodine	
3·2	Iodine		4·2	Selenium, mercury, iron and copper	
3·3	Manganese		5	Total Concentration of Trace Elements, Fe, Cu, Zn and Se in Seawater	138
3·4	Molybdenum and tungsten				

## 1 Introduction

Marine chemists in Japan have made strenuous efforts to develop analytical techniques for determining trace elements in seawater. One of their notable contributions is that they have been able to exactly determine the concentration and distribution of trace elements in ocean water by employing recently developed clean sampling and treatment techniques. They have also established a number of exquisite techniques that

can be used to determine the chemical and physical forms of trace elements occurring in seawater. Research conducted by Japanese marine chemists in this field has been principally directed to the issue of valency states and organically-bound forms of trace elements. It has been shown that some oxyacid elements are present in more than two valency states and significant portions of various metals exist in organic form in seawater. Given these results, the factors controlling the behavior and cycling of trace elements in seawater have been considerably elucidated,

even though a complete understanding of these factors has not yet been realized. Marine chemists generally agree that this is an important area of research for a better understanding of chemical oceanography.

The present report is a synoptic reviews of progress in this field which has taken place in Japan.

## 2 Clean Sampling: Challenge to the Determination of ng Level Trace Elements in Seawater

One of the most successful achievements in marine chemistry in recent decades has been a clarification of the distribution of trace metals in seawater. This success may be attributed to the development of clean sampling and treatment techniques of seawater that totally eliminate the causes of contamination. Table 1 shows a chronological outline of the progress that took place in seawater analysis between 1965 and 1982. It can be seen that the estimated mean concentrations of trace metals have been revised showing a decrease of more than a multiple of ten when compared with recent data.

According to a short report by Patterson<sup>1</sup>, the reliability of lead concentration in seawater revealed in the literature was first questioned at a conference in Brookhaven National Laboratory in May, 1972, involving a project concerning international concepts for trace element analyses of seawater in terms of sampler, preserving container, and measuring instruments. The sampler must be free from objective elements and must be closed through casting. Also, the container should be neutral to the analytes or keep them in their authentic states, as occurs in seawater. Patterson also recommended isotope dilution mass spectrometry rather than atomic absorption spectrometry (AAS) or anodic stripping voltammetry since the latter is sometimes erroneous if a clean (contamination-free) condition is not maintained. In spite of Patterson's prediction, most analytical values with clean sampling have until now been given by AAS.

Boyle and Edmond carefully determined copper in surface seawater<sup>2</sup> and demonstrated that its concentration is well correlated with those of such nutrients as nitrate. They also measured the depth profile of cadmium in the North Pacific and found an excellent

correlation with that of phosphate.<sup>3</sup> Since their outstanding discovery in the mid 1970's, many oceanographers have been perplexed about the distribution of trace metals in seawater. Though many workers had been suspicious of the old data, it was not easy to determine the trace metal distribution in both surface and deep seawater. This situation is quite different from that cadmium, which is relatively easy to determine under a contaminant-free condition.

After tremendous efforts, Bruland and his co-workers published vertical distributions of zinc, nickel, copper and cadmium in the North Pacific.<sup>4</sup> In their work most of the samples were taken with Go-Flo (General Oceanics), a Teflon-coated 30-l ball-valve sampler made of polyvinyl chloride. The Go-Flo sampler was designed so that it can enter seawater while closed. Its ball valve opens at a depth of 10 m due to hydrostatic pressure. The sampler subsequently fills with seawater. Seawater flows through the inside of the sampler during its descent, until it reaches the sampling depth where the valve closes by a Teflon messenger. A stainless-steel wire is used as the hydroline for snatching and carrying the sampler, instead of the usual steel wire.

The system cited above was successfully operated and provided good results, through there still remained some drawbacks. In the first place, when determining the lead concentration it has been noticed that the shallow seawater shows a rather high concentration, suggesting the possibility of contamination in the course of passing the sampler through the upper layers of seawater. Secondly, the possibility that the stainless-steel wire emanates some metals, such as nickel and iron, is undeniable. In order to obtain the exact lead concentration in seawater, Patterson and his co-worker have produced a clean sampler which is called the "CIT sampler" after the name of the institute to which they belong.<sup>5</sup> A diagram of this sampler is shown in Fig. 1. Seawater is collected in Teflon tubing which is compressed to "zero" volume and maintained by a small amount of bath water, free from lead contamination until it is expanded before sampling. The CIT sampler is connected to the bottom end of the wire in

Table 1 Estimated mean value of trace element concentrations in seawater(ppb) appearing in the literature

Element	1965 <sup>10</sup>	1975 <sup>11</sup>	1982 <sup>12</sup>
Al	10	2	0.8
Mn	2	0.2	0.2
Ni	2	1.7	0.4
Cu	3	0.5	0.2
Zn	10	4.9	0.4
Pb	0.03	0.03	0.01
Cd	0.11	0.1	0.08

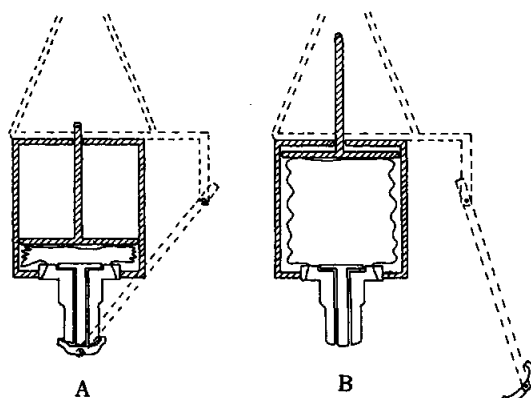

Fig. 1 Schematic diagram of the CIT sampler.<sup>6</sup>

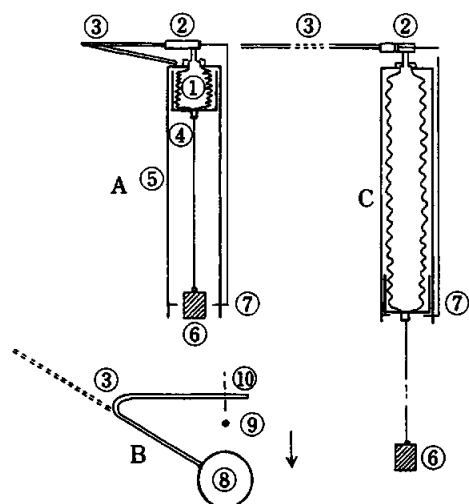

Fig. 2 Schematic diagram of the clean sampler made by Tsubota *et al.*<sup>6</sup> A, closed state; B, opened state for sampling (top view); C, open state for sampling (side view). 1, bellows type bag; 2, valve; 3, sampling tube for seawater inlet; 4, inside tube; 5, acrylic cylinder; 6, weight; 7, releaser for opened valve; 8, sampler; 9, wire; 10, the position.

order to avoid any pollution from the wire. Though the CIT sampler is one type of ideal clean sampler, a single hydrocasting can collect only one sample at a specific depth. If one determines trace metal distributions with this method, more than 10 repetitions of hydrocasting are required. While considering the previous types of clean samplers, Tsubota and his colleagues<sup>6</sup> developed a unique sampler which is both light in weight and is capable of multiple sampling with one hydrocasting. This sampler is shown in Fig. 2. Seawater is introduced into a bellows made of low-density polyethylene with blowing restoration. It has been mentioned in reference papers<sup>6</sup> that the material of the bellows was chosen after cautious and repetitive examination. The polyethylene bellows bag is folded before sampling and is protected inside the acrylic cylinder. When the messenger hits the trigger, it releases the polyethylene pipe (seawater entrance); this pipe is oriented and stretched toward the upper stream of the seawater. Thus, the seawater at about 1 m upstream of the wire is drawn into the bellows by its extension downwards with the weight.

Recent studies have demonstrated several patterns in the distributions of trace metals in seawater. However, it should be noted here that these patterns were determined using the present sampling technique. However, the further development of clean sampling techniques is needed for a better elucidation of trace element distributions in ocean water.

### 3 Inorganic Species of Trace Elements in Seawater

The inorganic species of trace elements dissolved in

seawater have been actively studied for oxyacid elements since the 1960's in Japan. The results of recent studies clearly show that some oxyacid elements such as Cr, I, Se, Te, As and Sb are present in more than two valency states in seawater. Sillen's classic thermodynamic calculation suggests that these elements could exist solely in their own stable higher valency states in oxygenated natural water.<sup>10</sup> The occurrence of lower valency states of these elements is attributed to a non-equilibrium process which may be related to biological activities; that is, it depends on the kinetics of reaching the thermodynamic equilibrium in seawater after being reduced to lower valency states, mainly through biological processes.

#### 3.1 Chromium

It is generally accepted that the predominant species of chromium in seawater is in the hexavalent state, which is thermodynamically stable; a small portion of dissolved chromium also exists in the trivalent state.<sup>11,12</sup> The total concentration of chromium in seawater ranges from 2 to 5 nmol l<sup>-1</sup>. Trivalent chromium can exist in inorganic, organically-bound (org. Cr) and particulate forms. Inorganic Cr(III) may exist as a mixed ligand complex, such as Cr(OH)Cl<sup>+</sup>, though it has been calculated as being mainly in a hydroxyl complex, Cr(OH)<sub>2</sub><sup>+</sup>.<sup>13</sup>

In analyses of inorganic Cr(III) and Cr(VI), the following information should be taken into account. Trivalent chromium is easily adsorbed on the container wall: This should not be prevented by the addition of mineral acid, since acidification may result in confusing results concerning the dissolved state of chromium. For example, a part of Cr(VI) could be reduced by coexisting organic materials under acidic condition. Also, immediate filtration after sampling is required in order to separate particulate Cr. The inert nature of hydrated Cr(III) restricts the method for its preconcentration. For such reasons, coprecipitation with metal hydroxides has been widely employed to concentrate Cr(III) and Cr(VI) in seawater.<sup>11,12</sup> In the coprecipitation method chromium species are determined as Cr(III) and total Cr (Cr(III)+Cr(VI)) by graphite furnace atomic absorption spectrometry (GFAAS). Cranston *et al.* used Fe(III) and Fe(II) hydroxides at the natural pH of seawater for coprecipitation.<sup>11</sup> The principle of their method is based on the fact that only Cr(III) is recovered by Fe(III) hydroxide. The hexavalent chromium is reduced to Cr(III) by Fe(II) hydroxide and is subsequently recovered. Nakayama *et al.* used Fe(III) and Bi(III) hydroxides.<sup>12</sup> Both Cr(III) and Cr(VI) were recovered by Bi(III) hydroxide because of the formation of an insoluble Cr(VI) compound with Bi(III). The coprecipitation method is, however, very complicated and time-consuming. Furthermore, it has serious defects: a small portion of Cr(VI) is coprecipitated with Fe(III) hydroxide, inorganic complexes of Cr(III) may not completely be coprecipitated and a part of org. Cr

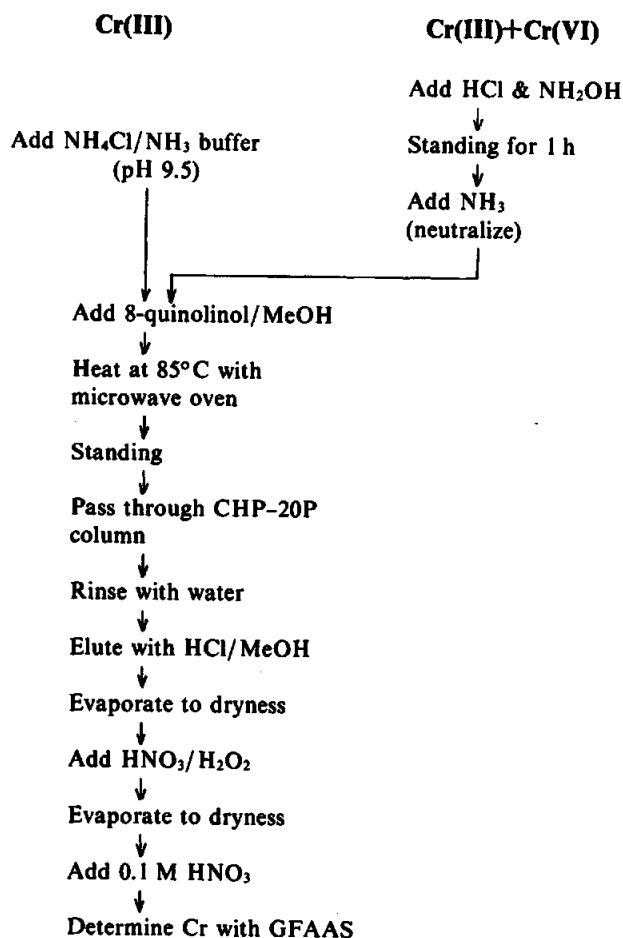

Fig. 3 Flow chart of the analytical procedure for the determination of chromium species in seawater.

could be recovered as inorganic chromium (as stated below). Solvent extraction and organic coprecipitation methods utilizing the active nature of Cr(VI) have been proposed. However, these methods are not desirable for obtaining sufficient accuracy in the determination of Cr(III), because the concentration of Cr(III) is usually far lower than that of Cr(VI) in seawater. The concentration of Cr(III) could be erroneously observed in measurements of Cr(VI) and total Cr.

Recently, Isshiki *et al.* have developed a column extraction method based on the complexation of Cr(III) with 8-quinolinol and the adsorption of the organic complex onto a macroporous resin.<sup>14</sup> A flow chart of the procedure is shown in Fig. 3. In this method, complexation is attained by mildly heating a sample, laying aside the problem of org. Cr. reduced into Cr(III) by hydroxylamine. With this method, chromium in seawater is successfully determined as Cr(III) and total Cr from a 500 ml seawater sample, laying aside the problem of org. Cr.

Figure 4 shows one example of the vertical distribution of chromium species obtained by this method. Total Cr exhibits a depletion in surface water, probably due to a reduction of Cr(VI) by the reducing organic

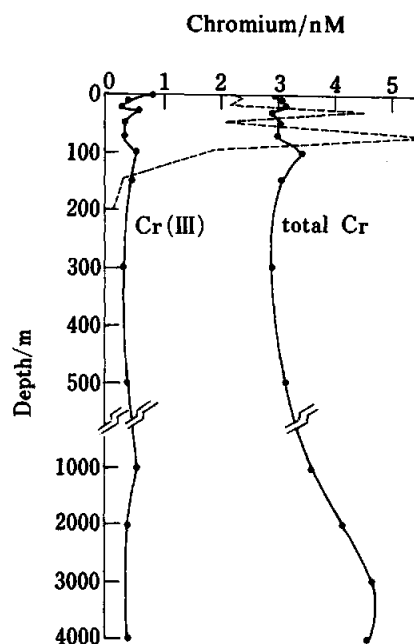

Fig. 4 Vertical profile of chromium species in the warm core ring off Sanriku.

material formed in the process of photosynthesis. Cr(III) distributes almost uniformly, whereas the concentration of Cr(VI) increases with depth. This is thought to be regeneration from the sea floor, where Cr(III) is oxidized to Cr(VI) by the catalytic effect of manganese(IV) oxide.<sup>15</sup>

### 3.2 Iodine

Iodine exists in seawater as iodide and iodate species.<sup>16-19</sup> The existence of a minor amount of organic iodine is also admitted. The major species is thermodynamically stable iodate. The total concentration of iodine in seawater is *ca.* 0.45  $\mu\text{mol l}^{-1}$ .

Iodine species in seawater have been determined by various methods such as the silver iodide precipitation method, catalytic spectrophotometry, neutron activation analysis, iodonium ion spectrophotometry and the polarographic method. In these methods, except for two methods that are very time-consuming, iodine species have been determined as iodate and total I (iodide + iodate). Since the concentration of iodide is often far lower than that of iodate in seawater, except for the euphotic zone, sufficient accuracy for the determination of iodide cannot be obtained with these methods.

Nakayama *et al.* have developed a new electrochemical technique for an automated determination of iodine species in natural waters.<sup>19</sup> A flow chart of the procedure is shown in Fig. 5. This method is based on the principle that iodide is electrochemically oxidized to molecular iodine and simultaneously adsorbed on a glassy carbon electrode and that iodide eluted from a carbon electrode is detected by a continuously polished

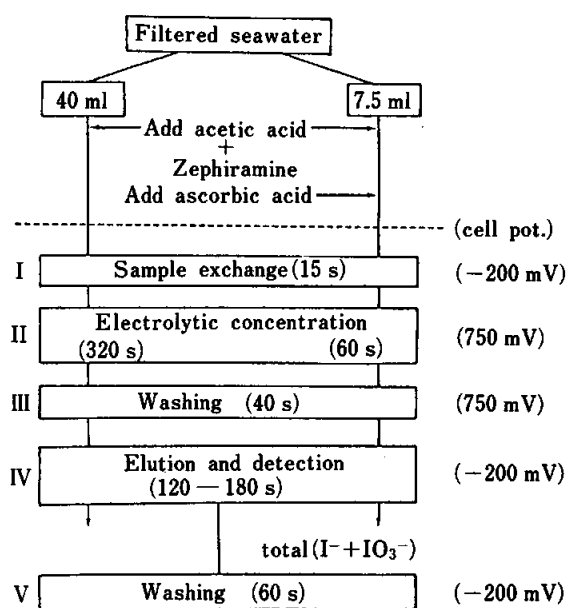

Fig. 5 Flow chart of the analytical procedure for the automatic determination of iodine species in seawater.

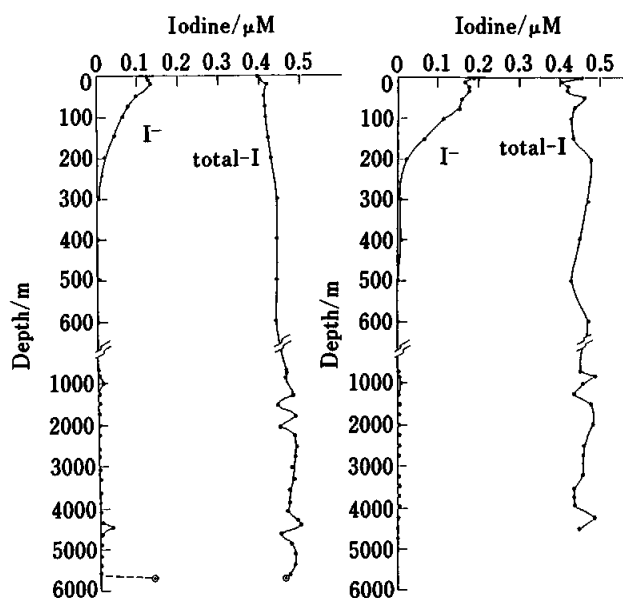

Fig. 6 Vertical profile of iodine species in the North Pacific Ocean.

$\text{Ag}_3\text{SI}$  electrode which is highly selective and sensitive to iodide. By this method inorganic iodine species can be accurately determined as iodide and total I from seawater samples of less than 50 ml.

Figure 6 shows typical vertical profiles of iodine species in seawater. Iodide exists only in the euphotic zone, whereas total I is distributed almost uniformly with a slight surface depletion and a minute excess in deep water. Iodate is reduced into iodide when a large amount of organic material is consumed by the nitrate

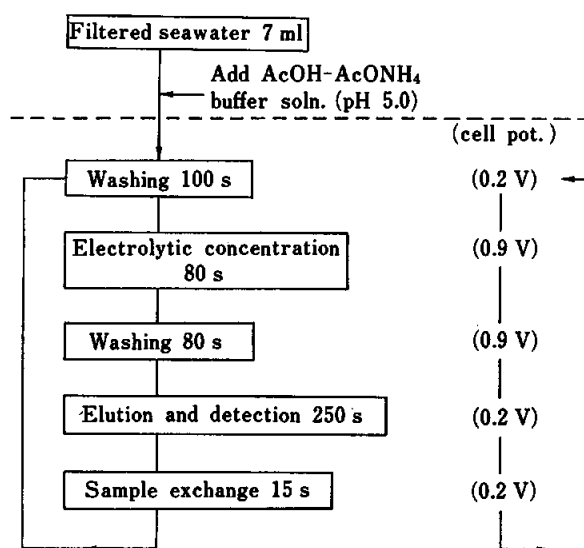

Fig. 7 Flow chart of the analytical procedure for the automatic determination of manganese in seawater.

respiration of bacteria.<sup>20,21</sup> Iodine species are regenerated from marine sediments. The oxidation process of iodide has not yet been confirmed.

### 3.3 Manganese

The dissolved state of manganese is considered to be only inorganic  $\text{Mn(II)}$  since thermodynamically stable  $\text{MnO}_2$  is the solid state. The existence of organically-bound manganese is not expected since the complexation ability of  $\text{Mn(II)}$  with organic ligands is very low. The concentration of manganese ranges from 0.5 to 4  $\text{nmol l}^{-1}$  in normal seawater. Occasionally, it reaches 10 to 20  $\text{nmol l}^{-1}$  in a dissolved oxygen minimum zone and a hydrothermal injection zone.

Manganese was determined by GFAAS method after concentrating by the solvent extraction with 8-quinolinol and the column extraction method with Chelex-100.

For a ship board analysis of manganese which is useful for probing hydrothermal activities, Nakayama *et al.* have developed a new automated analytical method which combines the electrolytic concentration with chemiluminescence (CL) detection.<sup>22</sup> A flow chart of the procedure is shown in Fig. 7. In this method,  $\text{Mn(II)}$  is electrochemically oxidized to manganese(IV) oxide and quantitatively adsorbed on a glassy carbon electrode in a manner similar to the above-stated method for iodine analysis. The manganese eluted from the electrode is detected by an improved CL method based on the oxidation of luminol with alkaline hydrogen peroxide. With this method, 0.3 to 20  $\text{nmol l}^{-1}$  of manganese can be accurately determined from seawater samples of less than 10 ml.

Figure 8 shows a vertical profile of manganese in Sagami Bay obtained using this method. Since Sagami Bay is located at the subduction zone of oceanic crust, a

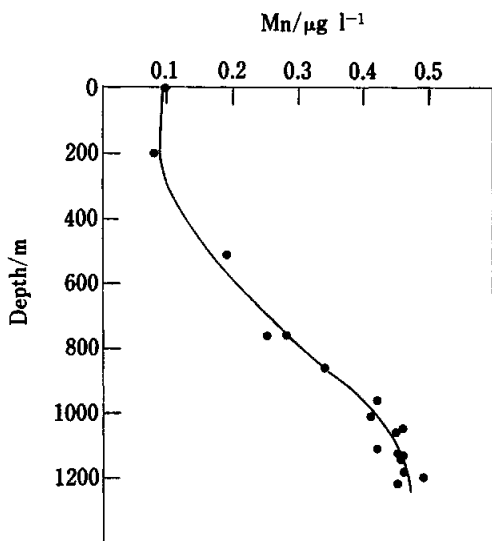

Fig. 8 Vertical profile of manganese at the Hatsushima site in Sagami Bay.

large seepage flux of manganese from the bottom has been observed.

### 3.4 Molybdenum and tungsten

Dissolved states of molybdenum and tungsten are simple oxyacids. Their organically-bound forms are not common because both of the oxyacids rarely form complexes with any organic ligands at a seawater pH around 8. It is well known that the concentration of molybdenum is almost constant both vertically and horizontally in seawater and is *ca.* 100 nmol l<sup>-1</sup>. However, the concentration of tungsten in seawater was not known until Sohrin *et al.* determined it as *ca.* being 60 pmol l<sup>-1</sup>, which corresponds to 1/1800 of that of molybdenum.<sup>23</sup>

Recently, Sohrin *et al.* have developed a method for simultaneously determining molybdenum and tungsten using improved catalytic current polarography after column extraction.<sup>23</sup> In this method both elements are concentrated with a Kelex-100 column, into which Amberlite XAD-4 resin (polystyrene-divinyl benzene copolymer) loaded with Kelex-100 (7-dodeceny-8-quinolinol) is packed.<sup>24</sup> The eluent is dissolved with a supporting electrolyte containing potassium chlorate, benzoic acid and 2-methyl-8-quinolinol. Both elements are determined from the peak current in a sampling DC polarographic mode. The catalytic currents are generated by cyclic electrochemical reduction and chemical oxidation of benzoic chelate of both the elements in the supporting electrolyte containing chlorate ions.

Figure 9 shows vertical profiles of molybdenum and tungsten. Their uniform distribution indicates that they are hardly incorporated into biological materials, unlike the so-called nutrient-type elements. The large difference in their concentrations can be explained by the removal rate with MnO<sub>2</sub>. Thus, the concentration

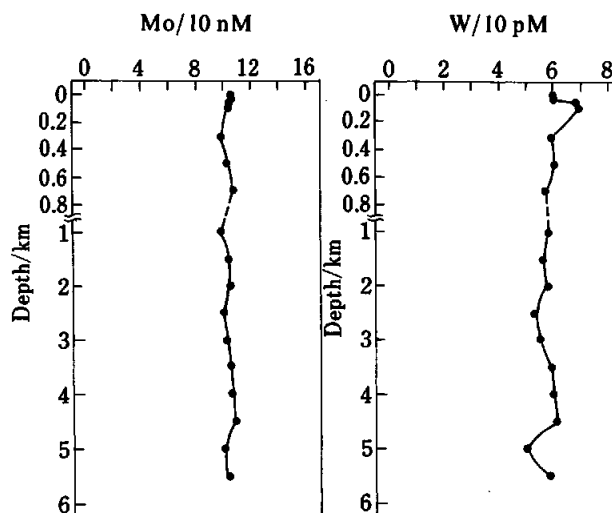

Fig. 9 Vertical profiles of molybdenum and tungsten in the North Pacific Ocean.

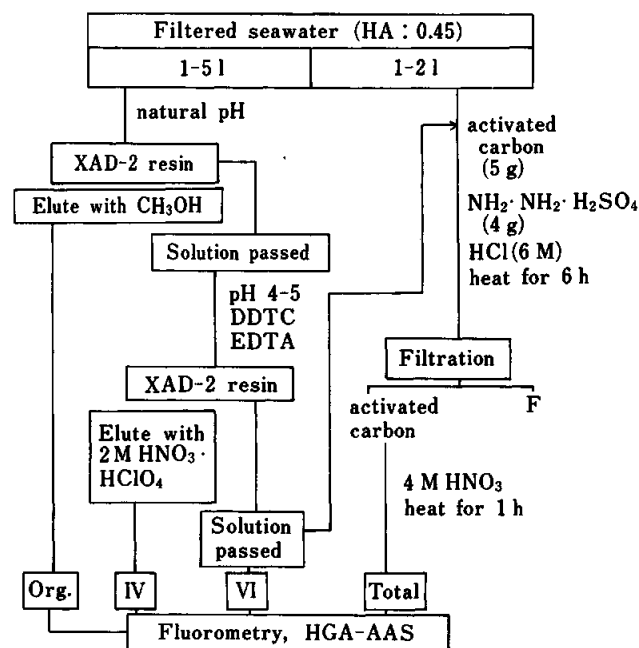

Fig. 10 Flow chart of the analytical procedure for the determination of selenium and tellurium species in seawater.

factor,

$$F = [M(\text{mol kg}^{-1})]_{\text{nodule}} / [M(\text{mol l}^{-1})]_{\text{seawater}}$$

of tungsten is *ca.* 200-times larger than that of molybdenum at pH 8.

### 3.5 Selenium and tellurium

Recently, Suzuki and Sugimura developed a new method for the chemical speciation of selenium and tellurium in seawater using Amberlite XAD-2 resin (polystyrene-divinyl benzene copolymer) and active carbon.<sup>25-29</sup> Four different chemical species can be separated by this method: particulate organic, dissolved

organic, inorganic-IV and inorganic-IV species. A flow chart of the method is shown in Fig. 10. Particulates Se and Te were separated with filtration (0.4  $\mu\text{m}$ ). Dissolved total Se and Te (organic + inorganic) were collected on active carbon with a reducing reagent in a hot acidic solution and an elution was made with hot nitric acid. Se(IV) and Te(IV) were separated by XAD-2 resin as diethyldithiocarbamic acid (DDTC) complexes from Se(VI) and Te(VI), respectively, in the seawater sample. Se(VI) and Te(VI) were extracted by a similar procedure to those of total Se and Te.

Selenium was determined by a fluorometric method, and Te by AAS coupled with hydride generation. Examples of the vertical profiles of Se and Te in different chemical species in seawater are shown in Fig. 11. It is evident that the different chemical species show different vertical profiles based on the different chemical natures. Also, the behavior of these elements is critically controlled by their chemical forms in seawater. Hiraki *et al.* carried out selenium speciation in seawater through coprecipitation with Fe(III) or Al(III) hydroxide.<sup>30</sup>

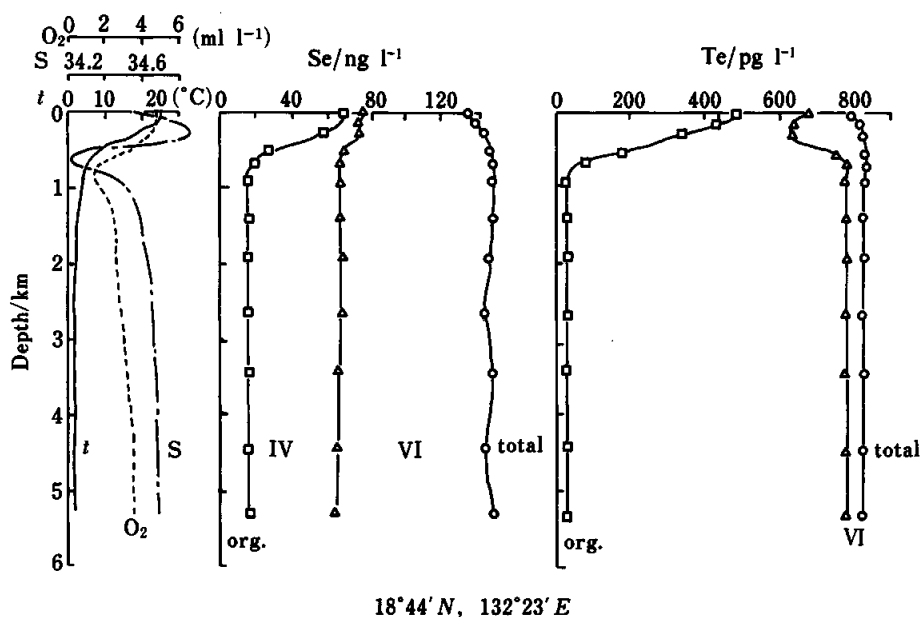

Fig. 11 Vertical distributions of selenium and tellurium species in seawater ( $18^{\circ}44'N$ ,  $132^{\circ}23'E$ ).

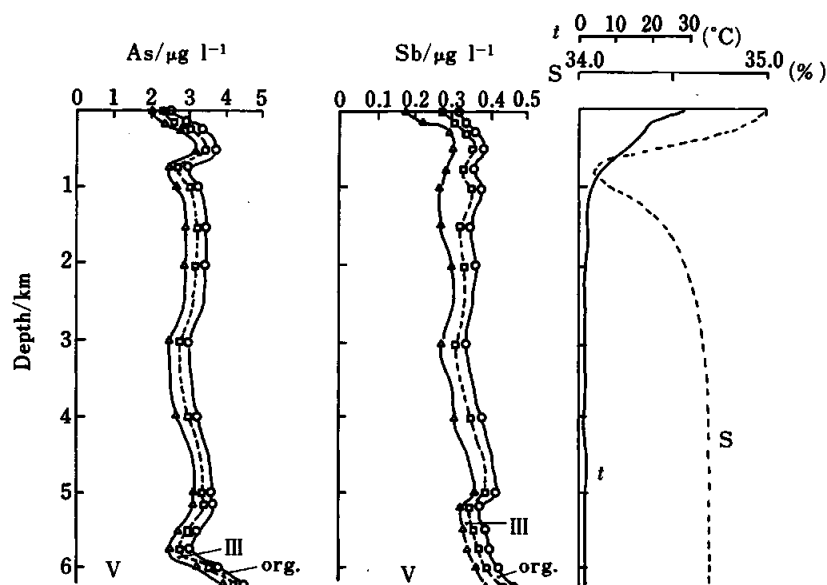

Fig. 12 Vertical distributions of arsenic and antimony species in seawater ( $30^{\circ}02'N$ ,  $147^{\circ}10'E$ ).

### 3-6 Arsenic and antimony

Chemical speciation of arsenic and antimony in seawater was achieved by Goda<sup>31</sup> and the coexistence of two inorganic valency states (III and V) was found. Though these studies were started earlier than those involving selenium, observations of the vertical profiles in the open sea have been poor. This is due to the lack of a systematic investigation concerning the analytical procedure for the chemical species of these elements in seawater. Suzuki has developed a new separation technique for arsenic and antimony species in seawater.<sup>32</sup> Examples of vertical profiles of As and Sb in the open sea are shown in Fig. 12. As(III) and As(V) and also Sb(III) and Sb(V) are separated from each other with a combination of XAD-2 resin and ammonium pyrrolidinedithioate (APDC)-complex, and their totals (As(III) + As(V) and Sb(III) + Sb(V)) are collected with active carbon in the presence of a reducing reagent. The proportions of chemical species of trace elements such as Se, Te, As and Sb are different from one another. The exact chemical forms of the inorganic species of these elements in seawater have not yet been confirmed. This is one of marine chemistry's most important challenges.

## 4 Organic Species of Trace Elements in Seawater

Any trace elements in seawater are involved in biological activities in the ocean. Inorganic nutrients (C, N, P *etc.*) are converted into organic compounds through assimilation. Trace metals incorporated in phytoplankton are also associated with organic materials in biological tissue or debris.

In recent years, it has been reported that significant portions of various trace elements in seawater exist in organic forms. The organic forms should basically be classified into coordinating-type and covalent-type. The coordinating-type organic species are so-called metal chelates or complexes with organic ligands. It has been considered that organic ligands existing in

seawater may be protein-like and humic acid-like substances. Table 2 shows the formation constants of various metals with some amino acids and salicylic acid. The former is a typical compound for protein and the latter for humic acid. The presence of copper-organic species is universally approved. This can be understood from the fact that the formation constants of copper are two to three orders of magnitude larger than those of the other monovalent and divalent metals, as shown in this table. Table 2 also, suggests that the presence of organic species of Cr(III), Fe(III) and Pd(II) is probable. Also, organic species of the other metals are not negligible since there may be some macromolecular ligands in seawater which may be strongly bound with metals through their own specific configurations, as found in the case of metallothionein.

The covalent-type organic species are organic compounds containing elements other than C, H, O, N and P in their molecules. Common examples of this type are a series of methylated compounds found for I, As, Ge, Se, Sb, Sn, Hg and Pb. Some of them are thought to be synthesized by organisms; for example, a copious amount of methyl iodide is observed on the algal bed.<sup>33</sup>

For determining the organic species, various methods have been applied. Solvent extraction was the first method used. Synthesized adsorbents, such as XAD-2 resin, C<sub>18</sub> Sep-Pack (octadecyl silica gel) and active carbon were extensively used to separate organic species directly from sample solutions. Though these methods are convenient for investigating the natures of organic species after separation, they have some disadvantages: water-soluble polar organic species are not completely recoverable, small portions of inorganic species may be adsorbed and additional complexation could occur on the adsorbents. Classical dialysis and ultra filtration with a membrane are promising methods for separating almost all parts of organic species in a sample solution, though they are time-consuming. It is, however, difficult to obtain a sufficient elucidation of the chemical speciation of trace metals in seawater, because these concentration techniques may result in a secondary transformation of the organic species, one from another, in the course of analyses. Differential pulse anodic stripping voltammetry and cathodic stripping voltammetry coupled with other techniques, such as MnO<sub>2</sub> coprecipitation and photo-decomposition methods, were found to be useful for the determination of the coordinating-type organic species. While useful for determining the abundance of the organic species, these methods are not sufficiently complete to supply information concerning their natures.

### 4-1 Chromium, germanium and iodine

Nakayama *et al.* reported that organic chromium accounts for 60% of total Cr.<sup>12</sup> This was, however, caused by the contamination from reagents used for digestion. In correction it was reduced to between 0 and 10% of total Cr by removing the contaminated chromium in the reagents. They defined organic

Table 2 Stability constants of metal-amino acid and -salicylic acid complexes (log  $K_f$  values)

Metal	Gly.	Ala.	Cys.	His.	Glu.	Sal.
Cu(II)	8.4	8.5	19.2	10.6	7.9	10.6
Ni(II)	6.4	6.0	10.5	8.5	5.6	7.0
Zn(II)	5.4	5.7	9.9	6.3	5.6	6.9
Pb(II)	5.1	4.2	12.8	6.0	4.6	—
Co(II)	4.7	5.0	9.3	6.9	—	6.7
Cd(II)	4.7	4.2	—	5.7	5.3	5.6
Mn(II)	3.9	3.2	4.6	3.6	3.3	5.9
Hg(II)	—	—	14.2	7.9	—	—
Ag(I)	3.5	3.6	—	—	—	—
Pd(II)	9.1	—	—	—	—	—
Fe(III)	10.0	—	—	4.7	12.1	16.4
Cr(III)	8.6	8.5	—	—	—	—



chromium as the species which is not coprecipitated with metal hydroxides and is recovered after digesting a sample solution. This is only based on the fact that some water-soluble chromium chelates are not coprecipitated with metal hydroxides. The existence of this species as organic chromium has not been verified. It could, therefore, be inorganic complexes. Hydrophobic organic species, like humic acid, can be coprecipitated with metal hydroxides. Therefore, a more reliable method should be developed to more accurately separate inorganic and organic species of chromium. In addition, chromium species recovered with XAD-2 are minute according to a investigation of Nakayama *et al.*

The distribution of inorganic germanium is well correlated with that of silicate. It was also found that monomethyl and dimethyl germanium exist in seawater and that monomethyl germanium is the predominant species of germanium, unlike silicate.<sup>34</sup> Both inorganic and organic germanium are simultaneously determined using a chain of hydride generation, gas chromatographic separation and GFAAS methods. This technique was also successfully applied to other elements such as As, Sn and Sb. Methylated compounds of germanium are very stable, and are not completely decomposed by wet-oxidation with oxidative mineral acids. The origin of these compound is one of the riddles of marine chemistry.

A number of organic iodine compounds such as methyl iodide, iodo alcohol and tyrosine derivatives have been found in marine organisms. However, only methyl iodide could be determined by the solvent extraction-gas chromatographic method.<sup>33</sup> Although the amount of organic iodine may be negligible, as compared with that of inorganic iodine, this should be determined so as to clarify the geochemical cycling of iodine. Nakayama *et al.* are planning to develop an analytical method for determining organic iodine using the above-stated electrochemical technique, in which inorganic iodine species are selectively recovered. It is noted that organic iodine can be converted to the inorganic form by photo-decomposition only after removing inorganic iodine species from the sample solution.

#### 4.2 Selenium, mercury, iron and copper

Trace metal speciation in seawater has been achieved using the adsorption of metal-organic complexes and covalent compounds onto XAD-2 resin by Sugimura and Suzuki.<sup>35-38</sup> Two types of metal-organic species were separated: one was adsorbed on the resin at pH 8 of seawater and the other at pH 3. The former was eluted with methanol and the latter with dilute  $\text{NH}_4\text{OH}$  at pH 10. Trace metals were determined by various conventional techniques, such as a spectrophotometric method and AAS. It has been reported that Se, Cu, Fe and Hg are present mostly as organic complexes or covalent compounds in seawater. The concentrations of these species are shown in Table 3. It should be noted that the real presence of organic trace elements

Table 3 Concentration of organic species of trace elements in seawater

	Organic species/ $\mu\text{g l}^{-1}$		Org./Total (%)	Total/ $\mu\text{g l}^{-1}$
	Neutral, Basic	Acid		
Fe	$0.32 \pm 0.18$	$0.47 \pm 0.22$	$78 \pm 14$	$0.98 \pm 0.21$
Cu	$0.28 \pm 0.12$	$0.05 \pm 0.02$	$72 \pm 11$	$0.46 \pm 0.12$
Se	$0.053 \pm 0.021$	—	$37 \pm 10$	$0.142 \pm 0.011$
Hg	$0.0049 \pm 0.0023$	—	$50 \pm 08$	$0.011 \pm 0.004$

Table 4 Distribution of metallic elements in three groups of organic matter (%)

Organic matters		Neutral, Basic	Acid
Lipid	Fe	7	1
	Cu	8	5
	Hg	31	0
Protein	Fe	24	0
	Cu	27	0
	Se	81	0
	He	69	0
Carbohydrate	Fe	11	57
	Cu	52	8
	Se	19	0

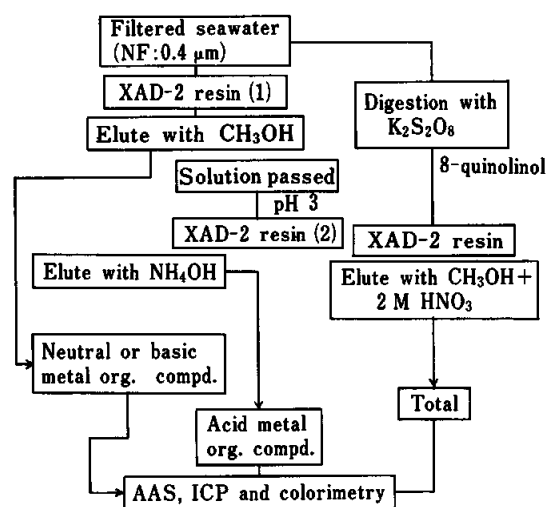

Fig. 13 Flow chart of the analytical procedure for the determination of organic species of trace elements in seawater.

cannot be detected directly. A flow chart of the analytical procedure is shown in Fig. 13. It is important to clarify the natures of the metal-organic species adsorbed on XAD-2 resin where the organic materials are lipid, protein and carbohydrate. The separation of the three organic groups was achieved by liquid extraction with methanol and  $\text{CHCl}_3$  for lipid, salting-out with 2 M  $\text{MgCl}_2$  followed by filtration with NF (nuclepore filter) for protein, and using a filtrate for carbohydrates. Results are shown in Table 4. The

distributions of these three organic groups of Fe, Cu, Se and Hg indicate that less than 20% of Fe and Cu are associated with lipid, more than 70% of Se and Hg with protein and 60% of Fe and Cu with carbohydrate. Suzuki reported that the mercury associated with organic materials in seawater accounts for 30 to 60% of total Hg.

Gel permeation-chromatography makes it possible to determine the molecular size distribution of organic mercury. Though several size groups of organic materials were observed with molecular weights ranging from  $10^3$  to  $10^5$  dalton, mercury was detected only in the limited group with a molecular weight of  $9 \times 10^3$  dalton. On the basis of these results, the presence of

alkyl mercury in seawater was examined.

It is important to clarify whether alkyl mercury exists as a monomer or macromolecular compound in seawater. Suzuki and Sugimura have determined alkyl mercury in seawater using the analytical procedure shown in Fig. 14.<sup>37,40</sup> The results of the examination concerning the presence of alkyl mercury in surface water are shown in Table 5. Alkyl mercury was not adsorbed on XAD-2 resin, was detected in fraction (C), but was not detected in fraction (D) of Table 5. A trace amount of alkyl mercury was detected by direct extraction from seawater (see E in Table 5). Table 5 suggests that the alkyl mercury compounds reported previously in open and coastal waters may be secondary products derived from macromolecular organic mercury compounds during the analysis.

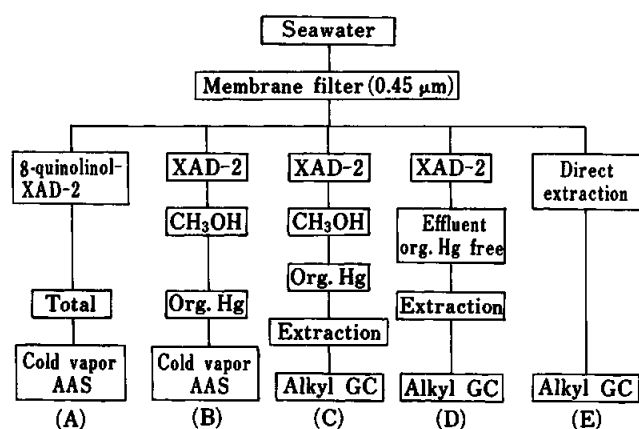

Fig. 14 Schematic procedure for an examination on the occurrence of alkyl mercury in seawater.

## 5 Total Concentration of Trace Elements in Seawater: Fe, Cu, Zn and Se

Exact measurements of the total concentrations of trace elements in seawater are very difficult because of the lack of the necessary informations for perfect chemical speciation of trace elements. The collection of organic species of trace elements from seawater is not easy when compared to that of inorganic species in seawater. One example of the recovery of organic forms of selenium in seawater by both previous and current methods used by Suzuki is shown in Table 6.<sup>28</sup> The current method is based on the adsorption on active carbon with a reducing agent in a HCl solution

Table 5 Results of an examination on the occurrence of alkyl mercury in surface water ( $\text{ng l}^{-1}$ )

Location	Total Hg (A)	Macromolecular Hg (B)	(C)	Alkyl Hg (D)	(E)
33° 30' N, 141° 30' E	9.4	3.7	0.43	<0.03	0.07
38° 31' N, 145° 29' E	8.7	2.6	0.59	<0.03	0.19
Sagami Bay	12.3	4.9	0.78	<0.03	0.10

(A) inorganic+organic (XAD-8-quinolinol method). (B) macromolecular organic Hg adsorbed on XAD-2 resin. (C) alkyl Hg in a sample of (B). (D) alkyl Hg in seawater of macromolecular organic Hg free. (E) alkyl Hg in original seawater.

Table 6 Recovery of organic forms of selenium in natural organic concentrate on XAD-2 resin in seawater by using two methods

Sample	Added organic form/ $\text{ng l}^{-1}$	Found			
		Previous method		Current method	
		$\text{ng l}^{-1}$	%	$\text{ng l}^{-1}$	%
(Western North Pacific)					
1	63	25 (64)	39	62 (66)	98
2	51	18 (78)	36	51 (80)	98
3	59	18 (70)	30	59 (70)	100
4	61	20 (70)	33	61 (71)	100
5	67	16 (62)	25	66 (64)	99

( ): values of inorganic form of selenium=dissolved total-organic form.

Table 7 Results determined of total concentration of trace metals in seawater by three different extraction method

Element	XAD-8-quinol.	Chelex	DDTC-CHCl <sub>3</sub>
	(8.0)	(7.2)	(8-9)
Fe	0.87	0.21	0.34
Cu	0.42	0.09	0.082
Zn	0.86	0.19	0.016

Figures in parentheses indicate pH value.

and the previous method of coprecipitation with tellurium and a reducing agent in a HCl solution. Recovery of organic selenium collected on an XAD-2 resin with the current method was 97% whereas that with the previous method was 33%. These results suggest that the low recovery of organic selenium species is due to its insufficient collection. They also clearly indicate that the total dissolved selenium concentration is underestimated by the previous method (coprecipitation method).

Another example by Suzuki is shown in Table 7 concerning the total concentrations of Fe and Cu in seawater.<sup>32</sup> Their total concentrations are quite different with three different preconcentration methods. Chelex-100 and DDTc extraction methods show lower values than that of 8-quinolinol-XAD 2. This indicates that trace elements strongly associated with organic compounds may not be extracted completely from seawater.

## References

1. C. Patterson, *Science*, **183**, 553 (1974).
2. E. Boyle and J. M. Edmond, *Nature* [London], **253**, 107 (1975).
3. E. Boyle, F. Sclater and J. M. Edmond, *Nature* [London], **263**, 42 (1976).
4. K. W. Bruland, R. P. Franks, G. A. Knauer and J. H. Martin, *Anal. Chim. Acta*, **105**, 233 (1979).
5. B. K. Schaule and C. C. Patterson, *Earth Planet. Sci. Lett.*, **54**, 97 (1981).
6. H. Tsubota, "*Kaiyou Kagaku Jiten*, (Encyclopedia of Oceanography, in Japanese)", ed. K. Wadachi, p. 219 Tokyodo Shuppan, Tokyo, 1987; S. Kanamori, H. Tsubota, M. Murozumi and S. Nakamura, "*Scientific Report for the Dynamic Structure of Ocean*", private publication, p. 223, 1985.
7. E. D. Goldberg, "*Chemical Oceanography*", 1st ed., Vol. 1, p. 164, ed. J. P. Riley and G. Skirrow, Academic Press, London, 1965.
8. P. G. Brewer, "*Chemical Oceanography*", 2nd ed., Vol. 1, p. 418 ed. J. P. Riley and G. Skirrow, Academic Press, London, 1975.
9. W. S. Broecker and T.-H. Peng, "*Tracers in the Sea*", A publication of the Lamont-Doherty Geological Observatory, p. 26, Columbia Univ., New York, 1982.
10. L. G. Sillen, "*Oceanography*", p. 549, Am. Asso. Adv. Sci. Publ., 1961.
11. R. E. Cranston and J. W. Murray, *Anal. Chim. Acta*, **99**, 275 (1978).
12. E. Nakayama, T. Kuwamoto, H. Tokoro and T. Fujinaga, *Nature* [London], **290**, 768 (1981).
13. H. Elderfield, *Earth Planet. Sci. Lett.*, **9**, 10 (1970).
14. K. Isshiki, Y. Sohrin, H. Karatani and E. Nakayama, *Anal. Chim. Acta*, in press.
15. E. Nakayama, T. Kuwamoto, S. Turubo and T. Fujinaga, *Anal. Chim. Acta*, **130**, 401 (1981).
16. S. Tunogai, *Deep-Sea Res.*, **18**, 913 (1971).
17. V. W. Truesdale and P. J. Smith, *Analyst* [London], **100**, 111 (1975).
18. K. Takayanagi and G. T. F. Wong, *Talanta*, **33**, 451 (1986).
19. E. Nakayama, T. Kimoto and S. Okazaki, *Anal. Chem.*, **57**, 1157 (1985).
20. S. Tunogai and T. Sase, *Deep-Sea Res.*, **16**, 489 (1969).
21. E. Nakayama, Y. Sohrin, K. Isshiki, T. Kimoto and S. Okazaki, *Mar. Chem.*, in press.
22. E. Nakayama, Y. Sohrin, K. Isshiki and H. Karatani, *Anal. Chem.*, in press.
23. Y. Sohrin, K. Isshiki, T. Kuwamoto and E. Nakayama, *Mar. Chem.*, **22**, 95 (1987).
24. K. Isshiki, F. Tsuji, T. Kuwamoto and E. Nakayama, *Anal. Chem.*, **59**, 2491 (1987).
25. Y. Sugimura and Y. Suzuki, *J. Oceanogr. Soc. Jpn.*, **33**, 23 (1976).
26. Y. Suzuki, Y. Sugimura and Y. Miyake, "*The Kuroshio-IV*", Proc. 4th CSK symp., Tokyo, Seikan Publ. Co., p. 396, Tokyo, 1979.
27. Y. Suzuki, Y. Miyake, K. Saruhashi and Y. Sugimura, *Pap. Met. Geophys.*, **31**, 185 (1979).
28. Y. Suzuki and Y. Sugimura, *J. Earth Sci. Nagoya Univ.*, **35**, 305 (1987).
29. Y. Suzuki, *Marine Science*, **17**, 570 (1985).
30. K. Hiraki and U. Nakaguchi, *Marine Science*, **17**, 540 (1985).
31. S. Goda, *J. Oceanogr. Soc. Jpn.*, **30**, 163 (1974).
32. Y. Suzuki, *Marine Science*, **14**, 292 (1982).
33. J. E. Lavelcock, *Nature* [London], **256**, 193 (1975).
34. G. A. Hambrick, P. N. Froelich, M. O. Andrea and B. L. Lewis, *Anal. Chem.*, **56**, 421 (1984).
35. Y. Sugimura, Y. Suzuki and Y. Miyake, *Deep-Sea Res.*, **25**, 306 (1978).
36. Y. Sugimura, Y. Suzuki and Y. Miyake, *J. Oceanogr. Soc. Jpn.*, **34**, 93 (1978).
37. Y. Sugimura, Y. Suzuki and Y. Miyake, "*Marine Radioecology*", ed. OECD-NEA, p. 131, Paris, 1980.
38. Y. Sugimura and Y. Suzuki, *Pap. Met. Geophys.*, **36**, 187 (1985).
39. Y. Miyake and Y. Suzuki, *Deep-Sea Res.*, **30**, 615 (1983).
40. Y. Suzuki and Y. Sugimura, "*Marine and Estuarine Geochemistry*", ed. A. C. Sigleo and A. Hattori, p. 259, Lewis Publ., Chelsea, 1985.

(Received October 31, 1988)

(Accepted March 9, 1989)