

## GAS FLARING IN INDUSTRY: AN OVERVIEW

Eman A. Emam

*Department of Chemical Eng. and Pet. refinery, Suez University, Egypt*  
[emamtah@yahoo.com](mailto:emamtah@yahoo.com)

Received August 24, 2015, Accepted December 3, 2015

---

### Abstract

Gas flaring is a combustion device to burn associated, unwanted or excess gases and liquids released during normal or unplanned over-pressuring operation in many industrial processes, such as oil-gas extraction, refineries, chemical plants, coal industry and landfills. Gas flaring is a significant source of greenhouse gases emissions. It also generates noise, heat and provided large areas uninhabitable. The World Bank reports that between 150 to 170 billion m<sup>3</sup> of gases are flared or vented annually, an amount value about \$ 30.6 billion, equivalent to one-quarter of the United States' gas consumption or 30 % of the European Union's gas consumption annually. Thus, a reduction or recover of gas flaring is a crucial issue. Therefore, there is a pressing need to measure flared gas by known its composition, distribution and volume, additionally, applied the suitable flare gas recovery system or disposal. This paper provides an overview of the gas flaring in industry and its composition, and its relevant environmental impacts. It also describes the flaring measurement techniques and the reduction of the flare gas by studying the different methods of flare gas recovery systems.

**Keywords:** gas flaring; greenhouse gas emissions; flared gas measurements; flared gas reduction; flare gas recovery systems.

---

### 1. Introduction

Gas flaring, the process of burning-off associated gas from wells, hydrocarbon processing plants or refineries, either as a means of disposal or as a safety measure to relieve pressure [1]. It is now recognized as a major environmental problem, contributing an amount of about 150 billion m<sup>3</sup> of natural gas is flared around the world, contaminating the environment with about 400 Mt CO<sub>2</sub> per year [2-3]. Losses from flares are the single largest loss in many industrial operations, such as oil-gas production, refinery, chemical plant, coal industry and landfills. Wastes or losses to the flare include process gases, fuel gas, steam, nitrogen and natural gas. Flaring systems can be installed on many places such as onshore and offshore platforms production fields, on transport ships and in port facilities, at storage tank farms and along distribution pipelines.

Gas flaring is one of the most challenging energy and environmental problems facing the world today. Nowadays world is facing global warming as one of its main issues. This problem can be caused by a rise in CO<sub>2</sub>, CH<sub>4</sub> and other greenhouse gases (GHG) emissions in the atmosphere. On the other hand, the flared gas is very similar in composition to natural gas and is a cleaner source of energy than other commercial fossil fuels [2]. Because of the increasing gas prices since 2005 and growing concerns about the scarcity of oil and gas resources the interest in flare gas has increased and the amounts of gas wasted have been considered. For example, the amounts of gas flared could potentially supply 50 % of Africa's electricity needs [2]. Thus saving energy and reducing emissions are become the worldwide requirement for every country. In addition, reducing flaring and increasing the utilization of fuel gas is a concrete

contribution to energy efficiency and climate change mitigation [4]. The purpose of this paper is to create an overview on the gas flaring in industry according to the following:

- gas flaring in industry and its composition,
- environmental impacts,
- measurement techniques by studying: government legislation; flow meter challenges; measurement technologies,
- different methods of flare gas recovery systems (FGRS), such as gas collection and compression; electricity generation and gas to liquid.

## 2. Gas flaring

The definition of gas flaring is by Canadian Association of Petroleum Producers as the controlled burning of natural gas that cannot be processed for sale or use because of technical or economic reasons [5]. Gas flaring can also be defined by the combustion devices designed to safely and efficiently destroy waste gases generated in a plant during normal operation. It is coming from different sources such as associated gas, gas plants, well-tests and other places. It is collected in piping headers and delivered to a flare system for safe disposal. A flare system has multiple flares to treat the various sources for waste gases [6-7]. Most flaring processes usually take place at the top of stack by burning of gases with the visible flame. Height of the flame depends upon the volume of released gas, while brightness and color depend upon composition.

Gas flaring systems are installed on onshore and offshore platforms production fields, on transport ships and in port facilities, at storage tank farms and along distribution pipelines. A complete flare system consists of the flare stack or boom and pipes which collect the gases to be flared, as shown in Figure 1 [8]. The flare tip at the end of the stack or boom is designed to assist entrainment of air into the flare to improve burn efficiency. Seals installed in the stack prevent flashback of the flame, and a vessel at the base of the stack removes and conserves any liquids from the gas passing to the flare. Depending on the design, one or more flares may be required at a process location.

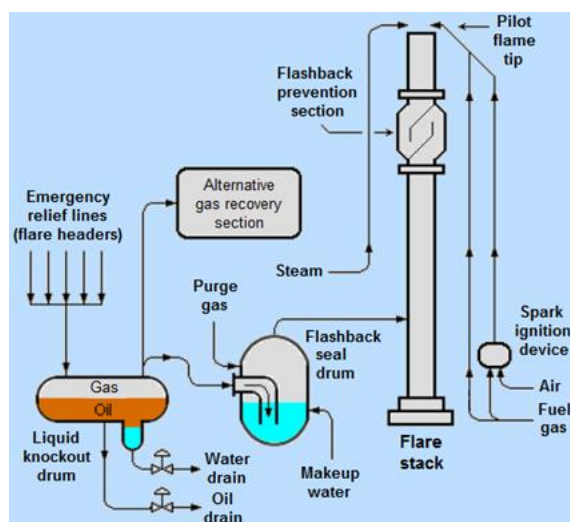

Figure 1 Overall flare stack system in a petroleum refinery [8]

A flare is normally visible and generates both noise and heat. During flaring, the burned gas generates mainly water vapour and  $\text{CO}_2$ . Efficient combustion in the flame depends on achieving good mixing between the fuel gas and air (or steam) [9], and on the absence of liquids. Low pressure pipe flares are not intended to handle liquids and do not perform efficiently when hydrocarbon liquids are released into the flare system [10].

Flaring processes can be classified into three groups: emergency flaring, process flaring and production flaring [11]. Emergency flaring can be occurred during the case of fire, break

of valves, or compressor failures. So, in a short duration of time, a large volume of gas with high velocity is burned. Process flaring usually comes with a lower rate, such as during petrochemical process some waste gases are removed from the production stream and then flared. Volumes of flared gas at such processes can vary during normal functionality and plant failures from a few m<sup>3</sup>/hr to thousands m<sup>3</sup>/hr, respectively [12]. Production flaring occurs in the exploration and production sector of oil-gas industry. Large volumes of gas will be combusted during the evaluation of a gas-oil potential test as an indication of the capacity of the well for production.

## 2.1. Gas flaring composition

Generally the gas flaring will consist of a mixture of different gases. The composition will depend upon the source of the gas going to the flare system. Associated gases released during oil-gas production mainly contain natural gas. Natural gas is more than 90 % methane (CH<sub>4</sub>) with ethane and a small amount of other hydrocarbons; inert gases such as N<sub>2</sub> and CO<sub>2</sub> may also be present. Gas flaring from refineries and other process operations will commonly contain a mixture of hydrocarbons and in some cases H<sub>2</sub>. However, landfill gas, biogas or digester gas is a mixture of CH<sub>4</sub> and CO<sub>2</sub> along with small amounts of other inert gases. There is in fact no standard composition and it is therefore necessary to define some group of gas flaring according to the actual parameters of the gas. Changing gas composition will affect the heat transfer capabilities of the gas and affect the performance of the measurement by flow meter. An example of waste gas compositions at a typical plant is listed in Table 1 [7].

Table 1 Waste gas compositions at a typical plant [7]

Gas flaring constituent	Gas composition, %	Gas flaring, %		
		Min.	Max	Average
Methane	CH <sub>4</sub>	7.17	82.0	43.6
Ethane	C <sub>2</sub> H <sub>6</sub>	0.55	13.1	3.66
Propane	C <sub>3</sub> H <sub>8</sub>	2.04	64.2	20.3
n-Butane	C <sub>4</sub> H <sub>10</sub>	0.199	28.3	2.78
Isobutane	C <sub>4</sub> H <sub>10</sub>	1.33	57.6	14.3
n-Pentane	C <sub>5</sub> H <sub>12</sub>	0.008	3.39	0.266
Isopentane	C <sub>5</sub> H <sub>12</sub>	0.096	4.71	0.530
neo-Pentane	C <sub>5</sub> H <sub>12</sub>	0.000	0.342	0.017
n-Hexane	C <sub>6</sub> H <sub>14</sub>	0.026	3.53	0.635
Ethylene	C <sub>2</sub> H <sub>4</sub>	0.081	3.20	1.05
Propylene	C <sub>3</sub> H <sub>6</sub>	0.000	42.5	2.73
1-Butene	C <sub>4</sub> H <sub>8</sub>	0.000	14.7	0.696
Carbon monoxide	CO	0.000	0.932	0.186
Carbon dioxide	CO <sub>2</sub>	0.023	2.85	0.713
Hydrogen sulfide	H <sub>2</sub> S	0.000	3.80	0.256
Hydrogen	H <sub>2</sub>	0.000	37.6	5.54
Oxygen	O <sub>2</sub>	0.019	5.43	0.357
Nitrogen	N <sub>2</sub>	0.073	32.2	1.30
Water	H <sub>2</sub> O	0.000	14.7	1.14

The value of the gas is based primarily on its heating value. Composition of flared gas is important for assessing its economic value and for matching it with suitable process or disposal. For example, for transport in the upstream pipeline network, the key consideration is the H<sub>2</sub>S content of the gas. Gas is considered sour if it contains 10 mol/kmol H<sub>2</sub>S or more [13].

## 3. Environmental impacts

Gas flaring is one of the most challenging energy and environmental problems facing the world today. Environmental consequences associated with gas flaring have a considerable impact on local populations, often resulting in severe health issues. Generally, gas flaring is normally visible and emitted both noise and heat. Ghadyanlou and Vatani [1] calculated the

thermal radiation and noise level as a function of distance from the flare using commercial software for flare systems. The results are presented in Table 2.

Table 2 Thermal and noise emissions from flaring [1]

Distance, m	Thermal radiation, kW/m <sup>2</sup>	Noise level, dB
10	5.66	86.3
20	5.87	86.19
30	6.04	86.02
40	6.14	85.78
50	6.17	85.50
60	6.14	85.18
70	6.04	84.83
80	5.88	84.46
90	5.67	84.08
100	5.42	83.68

The technology to address the problem of gas flaring exists today and the policy regulations required are largely understood. Global emissions from gas flaring stand for more than 50 % of the annual Certified Emissions Reductions (624 Mt CO<sub>2</sub>) currently issued under the Kyoto Clean Development Mechanisms [2]. However, flaring is considered as much safer than just venting gases to the atmosphere [2,13]. Pollutants of flare and their health effect are summarized in Table 3 [14].

Table 3 Pollutants of flare and their health effect [14]

Chemical name	Health effect
Ozone in land	In low densities eye will stimulate and in high densities especially children and adults it will cause respiratory problems.
Sulphide hydrogen	In low densities it will effect on eye and nose which result in insomnia and headache.
Dioxide nitrogen	It will effect on depth of lung and respiratory pipes and aggravates symptoms of asthma. In high densities it will result in meta-haemoglobins which prevents from absorption of oxygen by blood.
Particles matter	There is this believe that it will result in cancer and heart attack.
Dioxide of sulphur	It will stimulate respiratory system and as a result aggravating asthma and bronchitis.
Alkanes: Methane, Ethane, Propane	In low densities it will result in swelling, itching and inflammation and in high densities it will result in eczema and acute lung swelling.
Alkenes: Ethylene, Propylene	It will result in weakness, nausea and vomit.
Aromatics: Benzene, Toluene, Xylene	It is poisonous and carcinogenic. It influences on nerve system and in low densities it will result in blood abnormalities and also it will stimulate skin and result in depression.

CO<sub>2</sub> and CH<sub>4</sub> are GHG that, when released directly into the air, traps heat in the atmosphere. The climate impact is obvious, suggesting a great contribution to global GHG emissions. For example, about 45.8 billion kW of heat into atmosphere of Niger Delta from flared gas daily released [15]. As a result of the environment, gas flaring has raised temperatures and rendered large areas uninhabitable. CO<sub>2</sub> emissions from flaring have high global warming potential and contribute to climate change. CO<sub>2</sub> emissions come from only the combustion of fossil fuels for about 75 % [6]. CH<sub>4</sub> is actually more harmful than CO<sub>2</sub>. It has about 25 times greater global warming potential than CO<sub>2</sub> on a mass basis [13]. It is also more prevalent in flares that burn at lower efficiency [15]. Therefore, there are concerns about CH<sub>4</sub> and other volatile organic compounds from different operations.

Other pollutants such as sulfur oxides ( $\text{SO}_x$ ), nitrogen oxides ( $\text{NO}_x$ ) and volatile organic components (VOC) also released from flaring [1,6,16-19]. Ezersky and Lips [19] studied an emissions in US from a number of oil refinery flare systems in the Bay Area Management District (California). They concluded that, the emissions ranged from 2.5 to 55 tons/day of total organic compounds, and from 6 to 55 tons/day  $\text{SO}_x$ . Therefore, flare emissions may be a significant percentage of overall  $\text{SO}_2$  and VOC emissions. In addition, gaseous pollutants like  $\text{SO}_2$  that are once emitted into the atmosphere have no boundaries and become uncontrollable and cause acid deposition. Several toxicological/epidemiological investigations during the last few decades have shown that the effect of this gas is severe.  $\text{SO}_x$  and  $\text{NO}_x$  are the major causes of acid rain and fog which harm the natural environment and human life [20]. Also ozone has been revealed to cause damage. Ozone is also produced by the photochemical reaction of VOC and  $\text{NO}_x$  as the main components of the oxidant. The oxidant accelerates the oxidation of  $\text{SO}_2$  and  $\text{NO}_x$  into toxic sulfuric and nitric acids, respectively. The removal of VOC and NO is very important to reduce the concentration of ozone [21].

On the other hand, a smoking flare may be a significant contributor to overall particulate emissions [22]. Because the most flared gas normally has not been treated or cleaned, pose demanding service applications where there is a potential for condensation, fouling (e.g., due to the build-up of paraffin wax and asphaltine deposits), corrosion (e.g., due to the presence of  $\text{H}_2\text{S}$ , moisture, or some air) and possibly abrasion (e.g., due to the presence of debris, dust and corrosion products in the piping and high flow velocities) [23].

The quantity of the generated emissions from flaring is dependent on the combustion efficiency [9]. The combustion efficiency generally expressed as a percentage is essentially the amount of hydrocarbon converted to  $\text{CO}_2$ . In other words, the combustion efficiency of a flare is a measure of how effective that flare is in converting all of the carbon in the fuel to  $\text{CO}_2$ . There are some factors effects in the efficiency of combustion process in flares such as heating value, velocity of gases entering to flare, meteorological conditions and its effects on the flame size [24]. Properly operated flares achieve at least 98 % combustion efficiency in the flare plume, meaning that hydrocarbon and CO emissions amount to less than 2 % of species in the gas stream [25], demonstrated that properly designed and operated industrial flares are highly efficient. Many studies concluded that flares have highly variable efficiencies between 62 - 99 % [26-27]. In order to increase the combustion efficiency, the steam or air is used as assistant in flares, which create a turbulent mixing, and better contact between carbon and oxygen [28]. Excess air has implications on emissions, specifically related to the creation of  $\text{NO}_x$ . The availability of extra nitrogen found in the air and additional heat required to maintain combustion temperatures are favourable conditions for the formation of thermal NO [29]. More-over, greater amounts of excess air create lower amounts of CO but also cause more heat loss [9]. As a results from the above, gas flaring has a significant impact on environment due to possible presence of many harmful compounds. The scale of impact depends on the flared gas composition [9]. The impacts of flare emissions can be concluded as the following [6,15-18]:

- the low quality gas that is flared releases many impurities and toxic particles into the atmosphere,
- harmful effects on human health associated with exposure to these pollutants and the ecosystems.
- products of combustion can be hazardous when present in high amounts,
- the waste gas contains  $\text{CO}_2$  and  $\text{H}_2\text{S}$ , which are both weakly acidic gases and become corrosive in the presence of water,
- acidic rain, caused by  $\text{SO}_x$  in the atmosphere, is one of the main environmental hazards,
- acid rains wreak havoc on the environment destroying crops, roofs and impacting human health,
- CO causes reduction in oxygen-carrying capacity of the blood, which may lead to death,
- uncontrolled  $\text{NO}_x$  emission could be injurious to health,

- when  $\text{NO}_x$  reacts with  $\text{O}_2$  in the air, the result is ground-level ozone which has very negative effects on the respiratory system and can cause inflammation of the airways, lung cancer *etc.*

#### 4. Gas flaring measurement techniques

Lack of monitoring equipment and limited oversight make it difficult to quantify the amount of gas flaring around the world. For example, about half of the flares have flow monitors in some regions of Russia [30]. In addition, many countries do not publicly report gas flaring volumes, leading to significant uncertainty regarding the magnitude of the problem [31]. Therefore, it may be in the producers or governments interest to limit access to data on gas flaring levels. Much of the official information on the amount of gas flaring comes from environmental ministries or statistical agencies within various governments. However, during the last decade, increased use of military satellites and sophisticated computer programs has been used to measure gas flaring. These efforts seek to correlate light observations with intensity measures and flare volumes to produce credible estimates of global gas flaring levels.

Enhancement the reliability, completeness and accuracy of flare data is expected to improve flare reduction activities and investments. Recently, an increased has been awareness by several countries worldwide towards emissions monitoring, measurement and reduction for both environmental and economical reasons. Furthermore, data improvements at the country level will support efforts of the Global Gas Flare Reduction (GGFR) Partnership to enhance the quality of data on flare and vent volumes at the global level [23]. The World Bank estimates that between 150 to 170 billion  $\text{m}^3$  of gases are flared or vented annually, an amount worth approximately \$ 30.6 billion, equivalent to 25 % of the United States' gas consumption or 30 % of the European Union's gas consumption per year [2-3,32-33]. The EPA estimates that the cost of compliance will rise to \$ 754 million/year by 2015 for gas wells alone [34]. Geographic shows that a small number of countries contribute the most to global flaring emissions. At the end of 2011, 10 countries accounted for 72 % of the flaring, and twenty for 86 % [8]. In 2012 Russia and Nigeria accounted for about 40 % of global flaring [35]. Major flaring countries around the world are shown on Figure 2 [35].

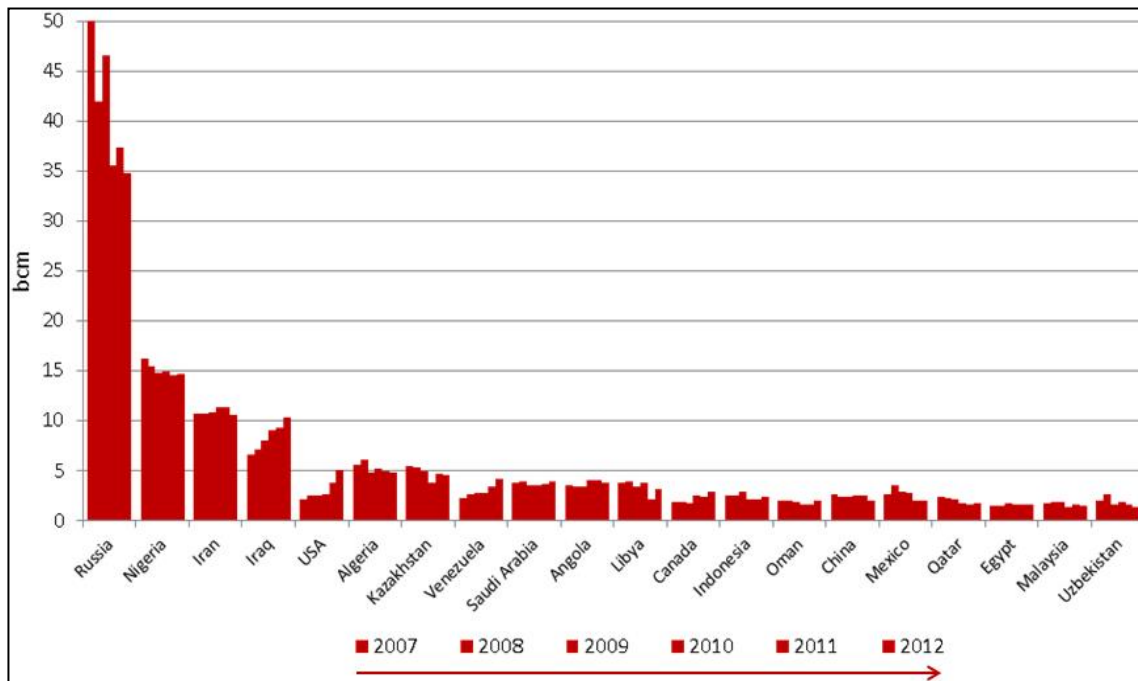

Figure 2 Top 20 gas flaring countries (NOAA satellite data) [35]

#### 4.1 Government legislation

Gas flaring and venting measurement has been identified as an important issue where the GGFR could make a meaningful contribution to the global flaring reduction agenda by collecting and disseminating a best practice [23]. On the Norwegian continental shelf, regulations were implemented in 1993 relating to the measurement of fuel and flare gas for calculation of CO<sub>2</sub> tax in the petroleum activities [36]. Recently, with gas prices elevated, and new government legislation on the horizon, producers, refineries and chemical plants have been looking for a cost effective solution to reduce emissions, and to provide control for both leak detection and mass balance.

The Alberta Energy and Utilities Board (EUB) guide 60 will soon be improved with regards to flare, and other regions in Canada are expected to follow suite [37-38]. The guide will state that measurement will be required for continuous or routine flare and vent sources at conventional oil-gas production and processing facilities where an average total flared and vented volumes per facility exceed 500 m<sup>3</sup>/day [38-39].

Acid gas flared, either continuously or in emergencies, will required to be measured from gas sweetening systems regardless of volume and fuel (dilution or purge) gas added to acid gas to meet minimum acid gas heating value requirements and SO<sub>2</sub> ground level concentration guidelines.

EUB Guide 60 references EUB Directive 017: Measurement Requirements for Upstream Oil and Gas Operations officially released February 1, 2005 [40]. In this directive it specifies the following uncertainties that must be met:

- measurement uncertainty for gas flaring must be  $\pm 5\%$ ,
- measurement uncertainty for dilution gas must be  $\pm 3\%$ ,
- measurement uncertainty for acid gas must be  $\pm 10\%$ ,
- accuracy specifications apply to the overall rangeability of the process conditions.

#### 4.2 Flow meter challenges

Gas flaring flow measurement applications present several unique challenges to plant, process and instrument engineers when selecting a flow meter system. There are many challenges when trying to measure gas flaring, including diameters of large pipe, high flow velocities over wide measuring ranges, gas composition changing, low pressure, dirt, wax and condensate. The applications of flared gas measurement have uniquely challenged with two various and critically important flow conditions: very low flow under normal conditions and sudden very high flows during an upset blow-down condition. Additionally, several other important criteria must be considered when selecting, constraints and considerations a flow meter for flared gas applications, plant operators, managers, process and instrument engineers, such as the following [23,34,39-41]:

- *Operating range*, the meter should be sized to accommodate the anticipated range of flows.
- *Accuracy*, the minimum required accuracy of the instrument will depend on the final use of the measurement data and applicable regulatory requirements.
- *Installation requirements*, the flow meter should be installed at a point where it will measure the total final gas flow to the flare and be located downstream of any liquids knock-out or disengagement drum.
- *Maintenance and calibration requirements*, all flow meters are susceptible to deteriorated performance with time and use; although, some are more robust than others.
- *Composition monitoring*, most types of flow meters are composition dependent. There are two primary options for composition monitoring: (1) sampling and subsequent laboratory analysis, or (2) the use of continuous analysis.
- *Temperature and pressure corrections*, the flow meter will need temperature and pressure compensation features to correct the measured flow to standard conditions (101.325 kPa and 15°C) or normal conditions (101.325 kPa and 0°C).
- *Multi-phase capabilities*, normal practice, if the gas stream contains high concentrations of condensable hydrocarbons, the gas flow meter should be installed as close as possible

to the knock-out drum and consideration should be given to insulating and heat tracing the line.

- *Monitoring records*, should be kept for at least 5 years. These records should be included the flow measurement data, hours the monitor during operation, and all servicing and calibration records. Periods of missed monitoring should be limited to 15 consecutive days and no more than 30 days per year.
- *Flow verification*, where verifiable flaring rate is desired, the systems should be designed or modified to accommodate secondary flow measurements to allow an independent check of the primary flow meter while in active service.
- *Flow test methods*, may be considered for making spot checks or determinations of flows in flare header.
- *Non-clogging, non-fouling, no moving parts* design for lowest maintenance.
- *Stainless steel wetted parts* and optional stainless steel process connections and enclosure housings.
- *Offshore platforms corrosive salt water*, may require use of stainless steel on all exposed instrument materials, including sensors, process connections and enclosures.
- *Agency approvals for installation in hazardous locations*, in environments with potential hazardous gases; enclosure only ratings are inadequate (and risky).
- *Compliance with local environmental regulations*, meet performance and calibration procedures mandated such as US EPA's 10 CFR 40; 40 CFR 98; EU Directive 2007/589/EC; US MMR 30 CFR Part 250 and others.

### 4.3 Measurement technologies

The flow meters are designed to confirm for very low flow measurement to detect the smallest of leaks and up to measure major upset conditions accurately at very high flows [34,42]. There are multiple air-gas flow measurement technologies to choose from. For example, some flow meter technologies are better at measuring liquids than air or gases. The accuracy of some flow meters is influenced by heat and some sensor technologies are temperature-compensated to maintain accuracy. Moving parts are acceptable in some operating environments and in other environments they can require high levels of maintenance or repair or replacement [42].

A listing of the main flow meter measurement options and a qualitative ratings is given in Table 4 [23,41]. The best choice will depend on the specific circumstances and application requirements. For existing flares it may be appropriate to first perform a manual measurement or estimation of the flow rate to assess the requirements of a permanent flow measurement system. For new applications, this approach may prove more expensive as installing equipment at a later stage is normally costly [23].

Mostly gas flaring will be wet and potentially dirty. The measurement technology will either need to be composition independent or easily corrected for variations in the gas composition, at facilities where gas processing is being performed or the produced gas is being supplied by a variety of sources having differing compositions. In the case of the correction with variations in the gas composition, regular gas analyses may need to be performed. The cost of installing a flow meter, the ability to do so without requiring a facility shutdown and the ongoing calibration requirements will also be important considerations. The cost of running electric power and communications wiring to an instrument was a major consideration; however, the use of solar panels and wireless connections to data acquisition systems may now be considered in these situations. Measurement technologies that do not require electric power and only provide local readout are also an option.

Varying gas composition, large pipe diameters, high flow velocities over wide measuring ranges, low pressure, dirt, wax, acid gases and condensate are many challenges when trying to measure gas flaring. For these reasons, traditional technologies such as insertion turbine meters, averaging pitot tubes, and thermal mass meters fall short of being an acceptable solution. Also, changing gas composition had no affect on ultrasonic meters, but the differential



meters were affected due to the square root calculation, and thermal meters influenced by the heating properties of the gas [32]. Ultrasonic technology was developed for flare gas measurement back in the early 1980s by Panametrics in collaboration with Exxon in Baytown, TX. Today ultrasonic flow meters are the industry standard for gas flaring measurement with more than 3000 installations worldwide in different plants at on- and offshore platforms [43-44].

Table 4 The main types of flow meter technologies for flare gas measurement in industry [23, 41]

Flow meter		Characteristics
Category	Type	
Inline	Differential pressure meter Common style: <ul style="list-style-type: none"> <li>• orifice meters</li> <li>• venturi meters</li> <li>• annubars</li> </ul>	<ul style="list-style-type: none"> <li>- high tolerate of wet or dirty gas</li> <li>- high calibration frequency</li> <li>- high flow capacity</li> <li>- high accuracy, from <math>\pm 1</math> to <math>\pm 5</math> % of full scale</li> <li>- no electric power required</li> <li>- rugged design</li> <li>- low rangeability</li> <li>- limited operating range</li> <li>- flow resistance</li> <li>- composition dependent</li> <li>- no moving parts, maintenance can be intensive</li> <li>- high installed costs</li> </ul>
Inline	Vortex shedding	<ul style="list-style-type: none"> <li>- moderate tolerate of wet or dirty gas</li> <li>- composition independent</li> <li>- moderate flow capacity</li> <li>- moderate rangeability (in the range 30:1)</li> <li>- accuracy, within <math>\pm 2</math> % under ideal conditions</li> <li>- low-pressure drops</li> <li>- no moving parts</li> <li>- low calibration frequency</li> <li>- high installed costs</li> <li>- electric power required</li> <li>- not suited with low flow velocity (or where Reynolds number &lt; 5000)</li> </ul>
Insertion	Insertion (velocity probe), Common style: <ul style="list-style-type: none"> <li>- thermal anemometer</li> <li>- micro-tip anemometer</li> <li>- Pitot tubes</li> </ul>	<ul style="list-style-type: none"> <li>- none to low tolerate of wet or dirty gas</li> <li>- low to moderate calibration frequency</li> <li>- composition dependent</li> <li>- moderate to high flow capacity</li> <li>- very low to high rangeability</li> <li>- moderate accuracy, from <math>\pm 1</math> to <math>\pm 3</math> %</li> <li>- electric power required (Pitot tubes, no required)</li> </ul>
Inline	Transit-time ultrasonic	<ul style="list-style-type: none"> <li>- moderate tolerate of wet or dirty gas</li> <li>- composition independent</li> <li>- high flow capacity</li> <li>- high rangeability (in the range 2000:1)</li> <li>- high accuracy, within <math>\pm 2</math> %</li> <li>- low calibration frequency</li> <li>- electric power required</li> <li>- no internal parts that can drift and cause inherent errors</li> </ul>
Insertion (large diameter lines (> 6 inch))	Optical	<ul style="list-style-type: none"> <li>- moderate tolerate of wet or dirty gas</li> <li>- composition independent</li> <li>- high flow capacity</li> <li>- high rangeability (in the range 2000:1)</li> <li>- high accuracy, within 2.5% to 7%</li> <li>- low calibration frequency</li> <li>- electric power required</li> </ul>
Inline		
Inline	Positive displacement meters "Bellows (or Diaphragm)"	<ul style="list-style-type: none"> <li>- none tolerate of wet or dirty gas</li> <li>- composition independent</li> <li>- low flow capacity</li> <li>- moderate rangeability (in the range 200:1)</li> <li>- very high accuracy</li> <li>- low calibration frequency</li> <li>- no electric power required</li> </ul>

Table 4 (cont.) The main types of flow meter technologies for flare gas measurement in industry

Flow meter		Characteristics
Category	Type	
Insertion	Rotameter	<ul style="list-style-type: none"> <li>- low tolerate of wet or dirty gas</li> <li>- composition dependent</li> <li>- low flow capacity</li> <li>- low rangeability (in the range 10:1)</li> <li>- low to moderate accuracy</li> <li>- low calibration frequency</li> <li>- no electric power required</li> </ul>
Inline	Turbine meter	<ul style="list-style-type: none"> <li>- none tolerate of wet or dirty gas</li> <li>- composition independent</li> <li>- moderate flow capacity</li> <li>- moderate rangeability (in the range 100:1)</li> <li>- very high accuracy</li> <li>- low calibration frequency</li> <li>- no electric power required</li> <li>- having moving parts</li> </ul>

Many flare meter installations require regular validation of calibration, either per plant regulation or for compliance with environmental laws. Conventionally this has required a cumbersome and costly project to remove the meter from service and return it to a lab, which is particularly testing if the meter is still be within calibrated specifications [42]. The designers provides a simple to use tool to verify the flow meter is still within calibration without extracting the meter from pipe. This system consists of a portable special ready flow sensor (which can be used with any number of flow meters) and an additional benchmark calibration document to which field verification samples are compared [41-42].

On the other hand, three different methods for estimating flow rates are provided, namely: gas-to-oil ratios (GORs), mass balances and process simulations [23,38]. The limitations and potential accuracies of these methods are provided, as well as recommendations for their use. The estimation methods are perhaps the most common ways currently utilized to assess flare volume in the absence of continuous metering. The required input activity data and factors are accurately known, where conditions are relatively stable, then high accuracy is not required. These estimation methods can offer an acceptable alternative to continuous flow measurements. It is also recommended that GOR values be developed based on at least 24 hr tests and that these results be updated annually for stable or well behaved wells that are able to meet the desired accuracy and repeatability targets (e.g., with  $\pm 15\%$  or better). GOR values should also be re-evaluated whenever noteworthy changes in production or pumping rates occur (e.g., greater than  $\pm 25\%$  of value) since this may impact the stability and magnitude of the well's GOR [23].

## 5. Gas flaring reducing and recovery

Environmental and economical considerations have increased the use of flare gas recovery systems (FGRS) to minimize the amount of gas being flared [1,10]. The recovery of flared gas reduces noise and thermal radiation, operating and maintenance costs, air pollution and gas emission and reduces fuel gas and steam consumption. In recent years, there has been an international direction to reduce gas flaring and venting through the World Bank global gas flaring reduction (GGFR) partnership and the global methane initiative (GMI) [13]. Several countries are now signatories on the GGFR partnership's voluntary standard for flare and vent reduction [45], and both the GGFR partnership and GMI actively promote demonstration projects to reduce flaring and venting [13]. Other regulations can be used to reduce flaring such as direct regulation include Norway, where there is an enforced policy of zero flaring [46] and North Dakota in the U.S., where oil producers will be required to meet gas capture targets or face having their oil production rates capped [47]. Additionally, the United Nations' Clean

Development Mechanism (CDM) by offering 'Certified Emissions Reductions' provides flaring and venting reduction projects [48].

Several steps may be help to reduce the flared gas losses such as: proper operation and maintenance of flares systems, modifying start-up and shut-down procedures. Also, eliminating leaking valves, efficient use of fuel gases required for proper operation of the flare and better control of steam to achieve smokeless burning all contribute to reducing flare losses. Recovery methods may also use to minimize environmental and economical disadvantages of burning flare gas. Recently, several technology in flare tip design offers the greatest reduction in flare loss [10]. Even in most advanced countries only a decade has passed from FGRS, thus the method is a new methods for application in refineries wastes. Of such countries active in FGRS are USA, Italy, the Netherlands, and Switzerland. Most FGRS has been installed based primarily on economics, where the payback on the equipment was short enough to justify the capital cost. Such systems were sized to collect most, but not all, of the waste gases. The transient spikes of high gas flows are typically very infrequent, meaning normally it is not economically justified to collect the highest flows of waste gas because they are so sporadic. However, there is increasing interest in reducing flaring not based on economics, but on environmental considerations [7]. There is a range of methods to reduce and recover flaring, it is summarized as the followings [6,16,23,49,50]:

1. *Collection, compression, and injection/reinjection*

- a. into oil fields for enhanced oil recovery;
- b. into wet gas fields for maximal recovery of liquids;
- c. into of gas into an aquifer;
- d. into the refinery pipelines;
- e. collection and delivery to a nearby gas-gathering system;
- f. shipping the collecting flared gas to treatment plants before subsequent use;
- g. using as an onsite fuel source;
- h. using as a feedstock for petrochemicals production;

2. *Gas-to-liquid (GTL)*

- a. converting to liquefied petroleum gas (LPG);
- b. converting to liquefied natural gas (LNG);
- c. converting to chemicals and fuels;

3. *Generating electricity*

- a. burning flared gas in incinerators and recovering exhaust heat for further use (generation and co-generation of steam and electricity).

Decision of flaring or processing of gas depends on gas prices. Gas flaring would be processed and sold if prices would remain high enough for a long period, and all required infrastructure could be built for gas processing and transportation [2]. On the other hand, in order to select the best method for flared gas recovery and reduction, operators must have a good understanding of how the flare gases are produced, distributed and best consumed at the production facility. FGRS have been also impeded by a number of technical challenges [7], such as a combination of highly variable flow rates and composition, low heating value and low pressure of the waste gases [1,3]. In the case of very large volumes of associated flared gas, gas-to-liquid (GTL) conversion this gas into more valuable and more easily transported liquid fuels, or production of liquefied natural gas (LNG) to facilitate transport to distant markets, are potential options [51-52]. Both GTL and LNG options require enormous capital investments of infrastructure and must process very large volumes of gas to be economic [13]. However, reinjection of the gas flaring has been successfully used at several sites to dispose of residual "acid-gas" (primarily hydrogen sulphide, H<sub>2</sub>S, and CO<sub>2</sub> with traces of hydrocarbons) from gas sweetening plants where the costs of reinjection are less than the costs of sulphur removal [52-53]. The use of flared gas to generate electricity for on-site use is a demonstrated option, but this approach is not always economic and can be limited by the on-site demand for electricity [54]. By contrast, the collection and compression of gas into pipelines for processing and sale is a well-established and proven approach to mitigating flaring and venting [13].

Rahimpour and Jokar [16] compared three methods for recovering the flared gas of Farashband gas processing plant in Iran. These methods are GTL production, electricity generation with a gas turbine and compression and injection into the refinery pipelines. The results showed that the electricity production gives the highest rate of return (ROR), the lowest payback period, the highest annual profit and mild capital investment.

With increasing awareness of the environmental impact and the ratification of the Kyoto protocol by most of the member countries, it is expected that gas flaring will not be allowed in the near future [6]. This will require significant changes in the current practices of oil and gas production and other processes [55]. As reported by the World Bank (2005), economic viability of flare gas recovery projects are constrained in many countries mainly due to high project development costs, lack of funding and lack of distribution infrastructure [56]. In Norway, several concepts and technologies of FGRS have been proven and extensively applied in offshore oil-gas production fields [57]. For example, the gas flaring is pumped back down into the reservoir, to maintain the pressure and flow rate of the oil being produced in the Oseberg field in Norway [2]. By reinjection the flared gas in the oil production industry, they are able to recover much higher percentage of oil than if they were to simply inject water for example [58]. Qatargas company has made significant progress flaring from its LNG trains in line with the increased national focus on flare minimization and the company's desire to reduce its emissions and carbon footprint [59]. Enhanced acid gas recovery and operational excellence initiatives on source reduction and plant reliability at Qatargas' older, conventional LNG trains have successfully reduced flaring by more than 70 % between 2004 and 2011 [59]. A summary of Qatargas engineering projects and their expected flare reductions and implementation time-lines is provided in Figure 3 [59].

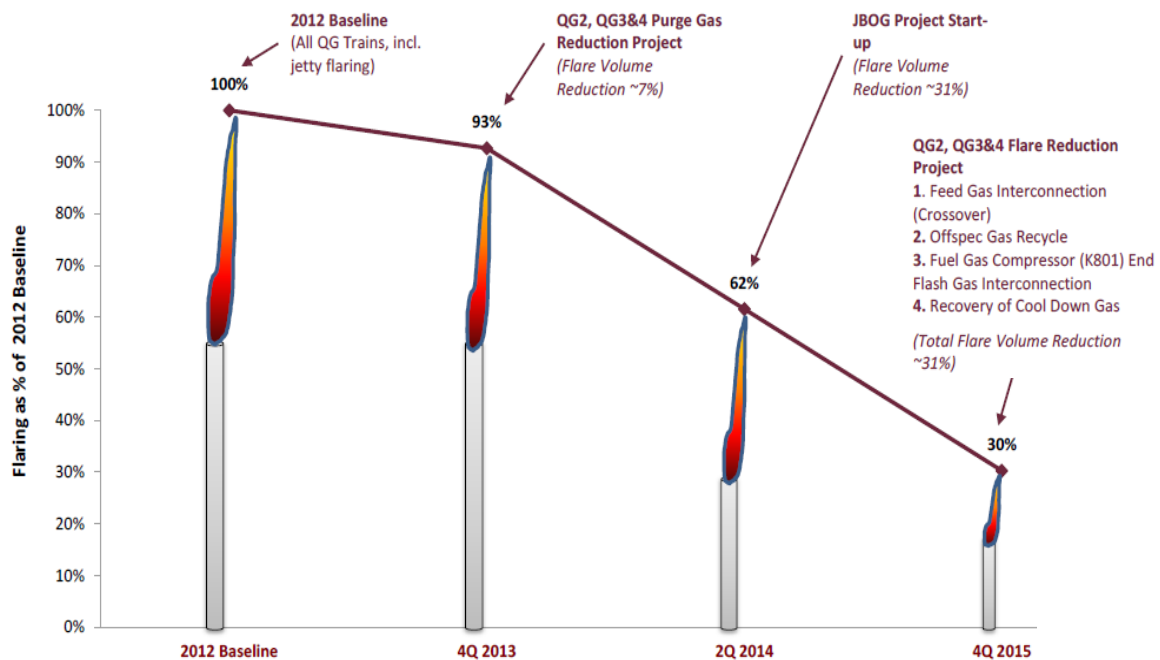

Figure 3 Summary of Qatargas flare reduction projects [39]

In Nigeria several efforts have been made to reduce gas flaring, including the establishment of a liquefied natural gas plant, a pipeline to transport gas to some neighbouring countries, and legislative measures to regulate the oil and gas industry [60]. According to Al-Blaies, Nigeria flared a total of 15.2 billion m<sup>3</sup> of gas in 2010, the second largest in the world [61]. When compared with the quantity of gas flared in 2005 there is about 29 % decrease in gas flaring in Nigeria, mainly due to the implementation of some flare reduction projects [60-61]. Even then, the quantity of gas flared in Nigeria is still substantive, and as at 2010, the country

remains one of the worst offenders when it comes to natural gas flaring, second only to Russia [60]. Since 2000, Shell Petroleum Development Company (SPDC) of Nigeria began an ongoing multiyear program to install equipment to capture gas from its facilities. In total SPDC flaring dropped by more than 60 % between 2002 and 2011 from over 0.6 billion ft<sup>3</sup>/day to about 0.2 billion ft<sup>3</sup>/day [15].

Tengizchevroil (TCO) executed with excellence multiple capital projects to reduce flaring (see Figure 4) [62]. TCO has invested \$ 2.8 billion on environmental programs over the last 14 years. Since 2000, TCO has reduced flaring volume by more than 93 %. At the same time, TCO has achieved a 99 % gas utilization rate and increased its oil production volumes by 158 % [63].

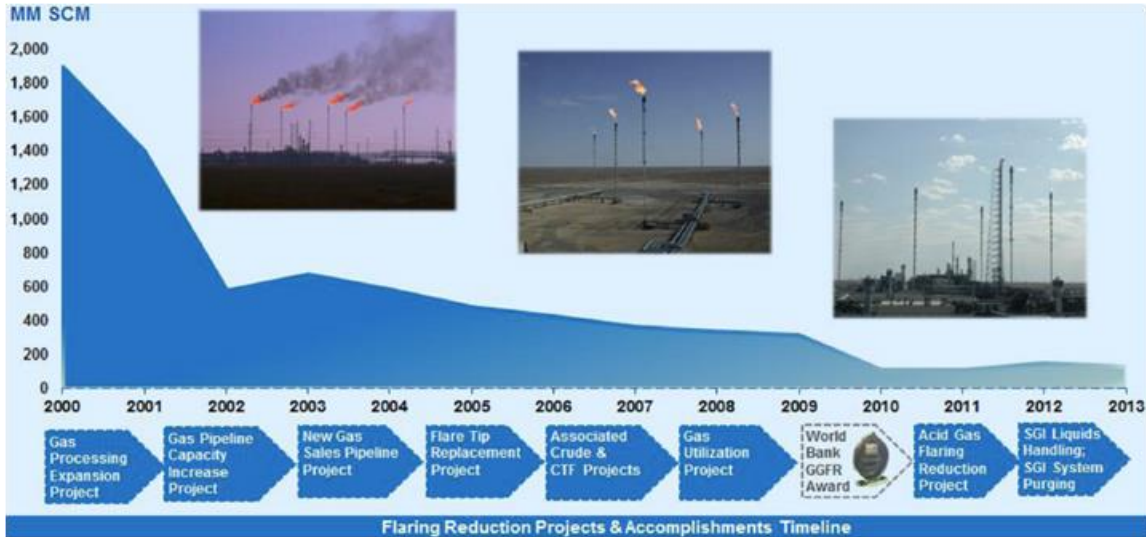

Figure 4 TCO gas flared from 2000 to 2013 [43]

### 5.1 Gas flaring collection and compression

The collection and compression of flared gas for transport in pipelines or other ways for processing and sale is a well-established and proven approach to reduce flaring and venting. During recent years in Iran, several projects have included the collection of associated gases [64]. In Alberta in 2008 [65], about 72 % from 9.72 billion m<sup>3</sup> of associated gas produced during production of oil and heavy oil was collected and sold into pipelines. An additional 21 % was used as onsite fuel (such as for process heaters or to drive natural gas fired compressors). The remaining amount of gas about 0.69 billion m<sup>3</sup> was flared or vented.

Tahouni *et. al.*, [66] integrated flared gas stream to the fuel gas network with waste and fuel gas streams in the refinery case study. A fuel gas network was collected fuel gases from various source streams and mixed them in an optimal manner, and supplied them to different fuel sinks such as furnaces, boilers, turbines, etc. This study proved that the optimal fuel gas network can be reduced energy costs and flaring emissions by using flared gas stream to the network.

Environmental and economic considerations have increased the use of FGRS to recover gases for other uses. By using recent technology in this field, a gas compression and recovery system (FGRS) can be used to reduce the volume of flared gases. Figure 5 shows a general view of a FGRS [67]. To recover flared gas, after collecting from flare header, it is diverted to the FGRS downstream of the knock-out drum by a liquid seal vessel and passes through a compressor. The compressed gas is then discharged into a mixed phase separator. The liquid is pumped through a heat exchanger and back to the service liquid inlet on the compressor. The compressed gas is separated from the liquid and is piped to the plant fuel gas header, or other appropriate location. The compressor recycle valve is regulated with control signals

based on the inlet flare gas pressure. This ensures that the flare header is under positive pressure at all times. In the event that the flow capacity of the FGRS is exceeded, the liquid seal vessel will allow the excess waste gas to go to the flare where it is safely burned [10]. Based on refinery structure or related unit, the compressed gases used as a feed or fuel. If required, to reach entrance gas temperature to FGRS and external gas temperature from this unit to an optional temperature, heat exchangers are used.

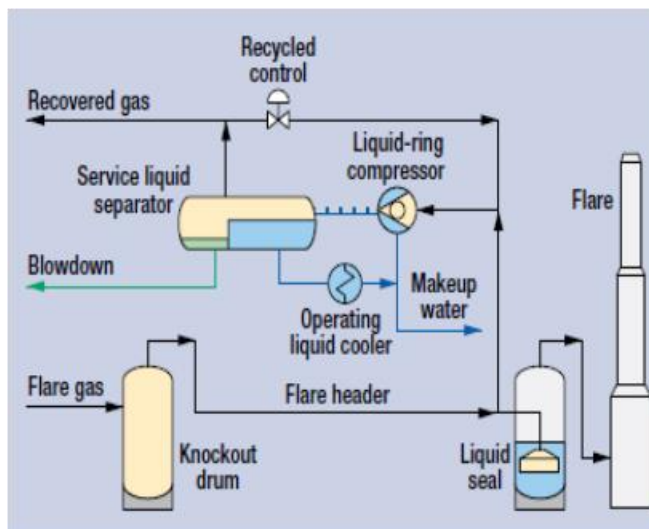

Figure 5 A view of a flare gas recovery system [48]

The compressor is the main part of the FGRS. The most suitable compressor design for FGRS depends on many factors such as initial cost, process requirements, physical size, efficiency, operating and maintenance requirements [49,68,69]. Over the last 35 years several compressor types including dry screw compressors (DSC), sliding vane compressors (SVC), reciprocating compressors (RC), liquid ring compressors (LRC) and oil injected (or oil flooded) screw compressors (FSC) both single and dual screw designs are used [6]. In general, LRC or RC are used to compress gases and to design FGRS. Advantage of LRC is that gas is cooled during compression by heat transfer of gas through fluid inside compressor (usually water). It is possible to use amine instead of water in such compressor to separate  $H_2S$  from flare gases [7]. LRC are also used because the design of the compressor can process two-phase flow that commonly exists in flare headers [10,69]. RC are purchased easily than LRC, also spare parts provision, repair and maintenance is much easier. If using RC, but it will explode if temperature exceeds over allowable limit [6,69,70].

FGRS are seldom sized for emergency flare loads. FGRS often are installed to comply with local regulatory limits on flare operation and, therefore, must be sized to conform to any such limits. The normal flare loads vary widely depending on the plants throughput and operating mode. To enable recovery of over 90 % of the total annual flare load and keep flaring to a practical minimum, the compression facilities should be designed to handle about 2 to 3 times the average normal flare load. In other plants, such as chemical plants, may have lower normal variation in flare rates [6]. For this reason, the installations may be sized for a lower flow range.

The composition of the flared gas is the strongest influence parameter on the FGRS. In general, changes in molecular weight in the gas stream going to the FGRS can generate the potential for overloading the compressor, leading to possible damage and a large increase in the specific heat ratio. Changing in molecular weight can also increase the gas discharge temperature after compression [1]. Generally, if the variation in the gas composition remains within the ranges specified in the data-sheet, the compressor performance can be achieved [71].

FGRS significantly reduced the GHG emissions from the different industries, and the harmful impacts normally associated with flaring. Duck [10] reported that about 60 MMBTU/hr of flare

gas was recovered by using FGRS in oil refining plant in Dushanzi-China. FGRS including LRC is a skid-mounted packaged system located downstream of the knock-out drum since all the flare gases are available at this single point. The results of using FGRS showed that, the plant prevented annually about 32.5, 176.8 and 67,000 metric tons of  $\text{NO}_x$ , CO and  $\text{CO}_2$  from being emitted to the atmosphere, respectively. Additionally, thermal radiation from the flames was greatly reduced which resulted in an increase in overall safety of the plant. Light and noise were also greatly reduced. Furthermore, the FGRS installation allows substantial cost savings because the recovered gases can be used as fuel or process feedstock. Assuming a fuel gas cost of \$ 5.00/MMBTU the plant will save more than \$ 5,000,000 per year on fuel gas costs if the FGRS operate at full capacity. With an expected operating cost of \$ 300,000 per year, the cost of the FGRS could be recovered in less than 9 months.

FGRS including LRC for reducing about 163,000  $\text{tCO}_2\text{e}/\text{year}$  of baseline emissions from Suez oil refinery company in Egypt was presented [3,72]. For about 94 % of gas emissions will be decreased [3] and a payback period of about 2 years [72]. Another FGRS in Farashband gas refinery in Iran, using piston compressors operate to recover about 4.176 MMSCFD of flared gas, provides a compressed natural gas with 129 bar pressure for injection to the refinery pipelines [16].

In Uran plant [4] (205 Km from the Mumbai High offshore field), FGRS was used to recycle all of the flare gases and process them to recover and utilize valuable hydrocarbon of about 30,000 - 150,000 SCMD from gas processing in order to achieve technical zero flaring. Screw compressor (oil flooded) was used in this FGRS and designed to capable of handling gases of molecular weight between 19.5 - 36.2 (flare gas molecular weight varies as per flaring from different plant and sources). FGRS has significantly reduced the  $\text{CO}_2$  emissions released into the environments. The total estimated reduction about 977,405  $\text{tCO}_2\text{e}$  from 2007 - 2008 to 2016 - 2017 considering the avoidance of 44 MMSCM of gas per year. Another FGRS at Hazira plant (232 Kms from the Mumbai offshore oil field) was designed to recover and utilize the tail gas of about 14,000 - 73,000 SCMD from gas processing plant in order to achieve technical zero flaring [4].

Zadakbar *et. al.* [64] presented the results of two case studies of reducing, recovering and reusing flare gases from the Tabriz Petroleum Refinery and Shahid Hashemi-Nejad (Khangiran) Natural Gas Refinery in Iran, including eleven plants of petroleum refineries, natural gas refineries and petrochemical plants. In the Tabriz petroleum refinery, the recommended FGRS includes two LRC, two horizontal 3-phase separators, two water coolers, piping and instruments. For about 630 kg/hr flare gas will be used as fuel gas by \$ 0.7 million capital investment corresponds to a payback period of about 20 months, and also 85 % of gas emissions will be decreased. In the Shahid Hashemi-Nejad (Khangiran) gas recovery, three LRC, three horizontal 3-phase separators, three water coolers, piping and instruments, proposed FGRS. For about 25000  $\text{m}^3/\text{hr}$  flare gas will be used as fuel gas by \$ 1.4 million capital investment corresponds to a payback period of about 4 months, and 70 % of gas emissions will be decreased.

Sangsaraki and Anajafi [6] studied the design criteria of FGRS and steady state and dynamic simulation of the FGRS. The recovery of 5916 normal  $\text{m}^3/\text{hr}$  of sweet natural gas, 24 ton/hr of gas condensates and production of 297  $\text{m}^3/\text{hr}$  of acid gas would be possible, according to steady state simulation results. Also, the changes in the temperature of the gases sent to the flare during total shutdown of the refinery as well as the impact it had on FGRS behavior was studied. It is obvious that the efficiency of the compressor is reduced due to the increase in the temperature of the gas sent to the flare network; therefore, the value of separation in two and three-phase separator shows a drastic change.

## 5.2 Gas-to-liquid technology

Gas-to-liquid (GTL) technology is one of the best methods for reducing gas flaring in the application of environmentally friendly technologies. It is one of the most promising topics in the energy industry by the conversion of flare gas to hydrocarbons due to economic utilization of control waste gas to environmentally clean fuels. Another environmental issue is the regu-

latory pressure to reduce the volume of flared gas, which has serious environmental consequences. Recently the development of GTL technology has been an increased interest. GTL technology plays an interest role in delivering gas to markets as both fuel and/or chemicals [73]. The products from GTL have interest environmental advantages compared to traditional products, giving GTL a significant edge as governments pass new and more stringent environmental legislation. So, conversion of flare gas (associated gas) to synthetic fuel has attracted more attention in some countries because of the economic and environmental benefits derive from it.

Gas flaring to liquids conversions can be achieved via several chemical reaction processes resulting in a range of end products. The Fischer-Tropsch (F-T) technologies are the most widely deployed [74]. In F-T technology, associated gas firstly pass through a steam methane reformer to produce syngas (a mixture of CO and H<sub>2</sub>). After that, syngas feeds into a F-T reactor that coverts to longer chain hydrocarbons (synthetic crude oil), water, and a "tail gas" comprising H<sub>2</sub>, CO and light hydrocarbon gases at an elevated pressure and temperature. The synthetic crude oil is then delivered to a conventional refinery for onward processing. The excess heat generated from the reaction has typically been removed by inserting boiler tubes that carry water. F-T products are of high quality, being free of sulfur, nitrogen, aromatics, and other contaminants typically found in petroleum products, which is especially true for F-T-gasoline with a very high octane number. However, drawbacks also exist for the F-T process: the capital costs of F-T conversion plants are relatively higher and the energy efficiency of producing F-T liquids is relatively lower than the one for other alternative fuels such as hydrogen, methanol, dimethyl ether and conventional biofuels [75].

In the history of F-T technology process development, the various types of reactors, including multi-tubular fixed bed reactor; bubble column slurry reactor; bubbling fluidized bed reactor; three-phase fluidized bed reactor; and circulating fluidized-bed reactor, have been considered [76]. The F-T process was first developed by Franz Fischer and Hans Tropsch used iron-based catalyst followed by using both iron and cobalt-based catalysts in Germany between 1920s and 1930s [77]. From 1950s to 1990s, South Africa SASOL developed F-T commercially (in conjunction with coal gasification) to convert coal to hydrocarbons with total capacity 4,000,000 Mt/year in three plants; two still in operation [78]. From 1980s to present, Shell using F-T to convert natural gas to fuels and waxes in Bintulu, Malaysia [79]. From 1980s to present, a number of entrants into the fields, a number of projects announced and planned (including demonstration projects), Qatar and Nigeria have started design and construction on world scale GTL facilities [80]. Oguejiofor discussed some aspects of using GTL technology for reducing flare gas in Nigeria [81]. The main issue in Nigeria is to gather gas from more than 1000 wells by building gas collection facilities at the oilfields and constructing an extensive pipeline network to carry gas to an industrial facility where it turns into liquids for transportation [82]. Gas flaring in Nigeria was reduced from roughly 49.8 % in 2000 to fewer than 26 % in 2006 [83].

A small scale simpler F-T processes can be deployed in small modular units to process associated gas [74]. The smallest potential plant evaluated by the study would convert 2000 - 10000 MCF/day of gas into 200 - 1000 bbls/day of liquid products [84]. A novel catalyst using atomic layer deposition in small-scale mobile systems was developed for convert low-value natural gas to high value synthetic crude oil (GTL) [85]. A novel catalyst yields 2.5-times more synthetic crude with high conversion about 90 % and low methane selectivity for about 6 wt% than state-of-the-art catalysts for GTL. Additionally, it is robust and has a low deactivation. Preliminary economic assessments predict that the scaled-up 100 bbl/day process using 1 MMSCFD natural gas, having a \$5 MM - \$7.5 MM total investment, would achieve a 15 - 30 % IRR at a breakeven price of \$20 - 75 per bbl depending on natural gas cost [85]. However, flared gas from the Farashband gas refinery in Iran is produced 563 bbl/day of valuable GTL products from the 4.176 MMSCFD of gas flared by GTL production [16].

The application of microchannel technology to F-T enables cost effective production at the smaller-scales appropriate for both onshore and offshore GTL facilities for stranded and associated gas reserves [79]. The microchannel technology to steam reforming of methane and F-



T synthesis using cobalt as catalyst was studied [79,86]. The steady state CO conversion was over 70 % and selectivity to methane was under 10 % [79]. The reactor operated steadily and had minimal change in conversion level even after 1,100 hr of operation [79]. Branco *et. al.* [87] estimated that total emissions from an offshore microchannel GTL plant in Brazil. The results showed that this plant allows the production of low-sulfur diesel, reducing gas flaring and co-producing high-quality naphtha, additionally, an average of \$ 37.00 per tCO<sub>2</sub>e reduced.

Knutsen [88] investigated the simulation of operational performance and optimization of a GTL plant based on autothermal reforming and a multi tubular fixed bed reactor together with a cobalt catalyst. The economics optimized process was found to produce of syn-crude with a carbon efficiency of about 77 % and thermal efficiency of about 62 %. Ultimately a production cost of \$ 16.10 per bbl and revenue of \$ 59.89 per bbl was obtained. With current crude oil price at \$ 98.90 per bbl it indicates a good economical environment for the GTL process.

Rahimpour *et. al.* [89] compared the performance of the two cascading membrane dual-type reactors in the form of fluidized-bed and fixed-bed for F-T synthesis. According to the results, fluidized-bed reactor is superior to fixed-bed reactor for F-T synthesis in GTL technology owing to achieving 5.3 % increase in the gasoline yield and 12 % decrease in CO<sub>2</sub> yield, in addition, excellent temperature control and a small pressure drop and consequently higher gasoline yield and lower CO<sub>2</sub> yield.

### 5.3 Electricity production

Power is a basic part of nature and it is one of the most widely used forms of energy. It is as a secondary energy source, from the conversion of many sources of energy such as coal, natural gas, oil, nuclear power and other natural sources. Natural gas was produced about 16 % of the power [90]. To be reduce the thermal emissions from several industry, such as petrochemicals, industrial gases, synthetic organic fibers, and agricultural chemicals, in which high-temperature exhaust is released that could be recovered for power generation [91]. The other method for FGRS is the conversion of flare gas as a primary source into electricity. An electric power station uses a turbine, engine, water wheel or other similar machines to drive an electric generator. A turbine converts the kinetic energy of a moving fluid (liquid or gas) to mechanical energy. Gas turbines are commonly used when power utility usage is at a high demand [90]. Gas flaring can be burned to produce hot combustion gases that pass directly through a turbine, spinning the blades of the turbine to generate power. Electricity generation with a gas turbine provides 25 MW electricity from the 4.176 MMSCFD of gas flared from the Farashband gas refinery in Iran [16]. Gas flaring can also be used to produce electricity in gas-fired turbines called "microturbines", to be an energy source to provide power for industry operations, like pumping, compression machines and gas processing. The electricity can even be sold, if they do not need all of it [92].

Two scenarios is described the electrical power generation by use of flared gas [93]. Gas turbine working in a simple Brayton cycle is a simulation of power generation in the first scenario. In the second scenario, cooling inlet air of a simple cycle of gas turbine by Fog method is added to improve the efficiency. Heydari *et. al.* [93] compared the two scenarios from both technical and economical point of view. The results indicate that, the power generation has a better situation in the second scenario, but the first one is more economically justified. The power generation in the first and second scenario are 38.5 MW and 40.25 MW respectively, while payback periods are 3.32 and 3.48 years. It should be also mentioned that, in order to increase the fuel pressure from 6 bar to 23.7 bar, a compressor with an efficiency of 90 % is used.

There are other cycles to generate power. Steam Rankine Cycle (SRC), the most commonly used system for power generation from waste heat involves using the heat to generate steam in a waste heat boiler, which then drives a steam turbine [91]. Steam turbines are one of the oldest and most versatile prime mover technologies. Organic Rankine Cycles (ORC), other working fluids, with better efficiencies at lower heat source temperatures, are used in ORC heat engines. ORCs use an organic working fluid that has a lower boiling point, higher vapor

pressure, higher molecular mass, and higher mass flow compared to water. So, the turbine efficiencies of ORCs are higher than in SRC. Additionally, ORC systems can be utilized for waste heat sources as low as 148 °C, whereas steam systems are limited to heat sources greater than 260 °C. ORCs have commonly been used to generate power in geothermal power plants, and more recently, in pipeline compressor heat recovery applications [91].

In 2007, the World Bank commissioned a large study by PFC Consulting to examine economic options for associated gas monetization in Russia [94]. Electric power generation and development of gas processing plants were found to be the most efficient ways to use flared gas. In addition, it was concluded that at a netback price of around \$1.42 per MMBTU close to 80 % of Russia's associated gas could be economically recovered [94].

Use of flared gas as a feed of fuel cell can be considered as a new approach to FGRS. Fuel cells are power-generation systems that convert directly the chemical energy of fuel to electricity. Among the various types of fuel cells, solid oxide fuel cell (SOFC) is more efficient [95]. SOFC is known as an environmental friendly power generation technology. SOFC is a kind of fuel cell contains two porous electrodes, which are separated by a nonporous oxide ion-conducting ceramic electrolyte. SOFC operates at temperatures between 600 - 1000 °C and uses H<sub>2</sub> containing gas mixture as a feed and O<sub>2</sub> of air as an oxidant [96]. The high operation temperature leads flexibility of using various fuel types such as methane, methanol, ethanol, biogas and etc. [97]. SOFC technology reduces CO<sub>2</sub> emission by about 55 %. Additionally there are approximately zero emissions of criteria pollutants (NO<sub>x</sub>, SO<sub>x</sub>, CO, particles and organic compounds) and very low noise emission. Saidi *et al.* [98] developed an electrochemical model for a steady-state, planar SOFC by considering the direct internal methane steam reforming for flare gas recovery of Asalouyeh gas processing plant in Iran. In this configuration, there is no pre-reforming and the sweetened flare gas is fed to SOFC directly. The using of this SOFC generates about 1200 MW electrical energy, and decreases the equivalent mass of GHG emission from 1700 kg/s to 68 kg/s. In addition, the total capital investment of this method is significantly lower than other no gas flaring approaches.

Tianjin Municipal Government in China [99] was initiated a project to recover landfill gas, which was otherwise being released into the atmosphere, and burn pretreated landfill gas for electricity generation or discharged to flaring. The produced landfill gas consists of 50 % CH<sub>4</sub> and 50 % other gases, such as CO<sub>2</sub> and additional gases including non-methane organic compounds. The project will obtain revenues from the sale of electricity which, over the project's life, will amount to \$ 36.2 million. The project has been registered as a CDM project under the Kyoto protocol and reached an agreement with the World Bank to purchase the certified emission credits (CERs) from the project.

#### 5.4 Other methods to reduce flaring

Many authors investigated the different methods of FGRS to reduce the emissions from different industries and reduce fuel costs, visible flame, odors and the auxiliary flare utilities such as steam. Mourad *et al.* [50] investigated the recovery of flared gas through crude oil stabilization by a multistage separation with intermediate feeds. Xu *et al.* [100] investigated a general methodology on flare minimization for chemical plant start-up operations via plant wide dynamic simulation. Ghadyanlou and Vatani [1] investigated methods to recover flare gases and thus reduce gas flaring in olefin plants. The case study concluded that significant amounts of ethylene about 43.3 Mt/hr and fuel gas about 10.8 Mt/hr can be recovered. Additionally, about \$ 9 million/year of valuable gases are returned to the plant and the investment costs are recovered after about three years of operation of the FGRU. Maung *et al.* [101] concluded that, the economic potential of using flared natural gas as a feedstock to produce a low-cost, reliable, and sustainable supply of nitrogen fertilizer for North Dakota farmers in the United States was examined.

For most processing plants the biggest problem has been removing the H<sub>2</sub>S in the natural gas. In the case where they couldn't remove it, the gas would be flared. If the gas contains too much sulfur it cannot be sold and flared. If the gas contains satisfies the requirements,

but still contains some sulfur, it is sold and burned by the consumers. Either way, the sulfur will contaminate and pollute the environment, creating acid rain and other problems, like supporting reactions that deplete the ozone in the stratosphere [102]. Reducing acid gas flaring was a high priority. Tengizchevroil (TCO) company [103] implemented and automated procedure to address this problem. The gas treatment process is a selective chemical absorption of  $H_2S$ , carbonyl sulfide and  $CO_2$  from the sour gas streams by diethanolamine. On the other hand, one of the newest technologies being used is bacteria that remove the sulfur from low volumes of sour gas [92]. The sulfur bacteria create a sustainable process that remove the sulfur compounds under highly alkaline and oxygen-limited conditions. Byproducts from the sulfate and thiosulfate will then be removed from the stream before being disposed of. This is also done by bacteria, but different ones, that remove sulfate and thiosulfate [102].

Where venting was a problem, companies would perform repairs and maintenance of the pipelines, but through new methods the flaring and venting have been cut down to nearly zero. An example of these methods is "hot tapping", which is a method used to prevent venting of natural gas when connecting pipelines [2]. Hot tapping makes it possible to work on a live system, such as pipes and pressure vessels without having to vent or shut down operations. Example of "hot tapping" vessel is shown on Figure 6 [2].

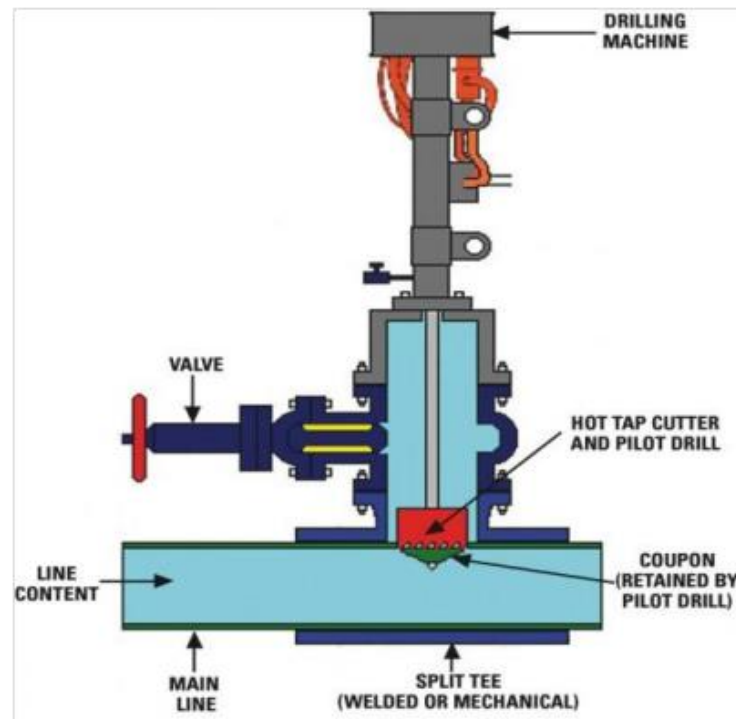

Figure 6. Hot tapping [16]

Rao *et. al.* [33] reported that by adopting new technologies of advanced process control with automation of steam control system, black carbon or soot from flare stacks can be minimized and save human being health from dangerous particulate matter emission from sooty flares. This automatic control system keeps always zero soot formation from the flare stack in any emergency situation.

Using some new environmentally friendly technologies reduces flare emissions and the loss of saleable liquid petroleum products to the fuel gas system. New waste heat refrigeration units are useful for using low temperature waste heat to achieve sub-zero refrigeration temperatures with the capability of dual temperature loads in a refinery setting. These systems are applied to the refinery's fuel gas makeup streams to condense saleable liquid hydrocarbon products [104].

## 6. Conclusions

Gas flaring is one of the most environmental problems through greenhouse gases and other emissions. These emissions have high global warming potential and contribute to climate change. Measurement of flared gas and its emissions are very important and has been very challenging. Several types of flow meter are used for measuring flared gas, however, ultrasonic flow meters are the industry standard for flared gas measurement with more than 3000 installations worldwide in different process plants. Flare gas reduction and recovery has high priority as it meets both environmental and economic efficiency objectives. There are many types of FGRS in industry such as gas collection and compression, gas-to-liquid, and generating electricity. FGRS have been impeded by a number of technical challenges, such as a combination of highly variable flow rates and composition, low heating value and low pressure of the waste gases. The gas collection and compression into pipelines for processing and sale is a well-established and proven approach to mitigating flaring and venting. According to environmental and economical considerations, FGRS have increased to reduce noise and thermal radiation, operating and maintenance costs, air pollution and gas emission and reduces fuel gas and steam consumption.

## References

- [1] Ghadyanlou, F.; Vatani, A.: Chemical Engineering, Essentials for the CPI Professional. 2015, chemengonline.com.
- [2] Andersen, R.D.; Assembayev, D.V.; Bilalov, R.; Duissenov, D.; Shutemov, D.: TPG 4140 – Natural Gas, Trondheim, Nov. 2012.
- [3] Abdulrahman, A.O.; Huisingh, D.; Hafkamp, W.: Journal of Cleaner Production 2015, 98, 116-122.
- [4] Deo, V.; Gupta, A.K.; Asija, N.; Kumar, A.; Rai, R.: 31 Oct.-3 Nov., New Delhi, India, Paper ID : 20100584, Petrotech-2010.
- [5] Canadian Association of Petroleum Producers, Flaring & venting, Retrieved Oct. 10, 2012, Available at:  
<http://www.capp.ca/environmentCommunity/airClimateChange/Pages/FlaringVenting.aspx>
- [6] Sangsaraki, M.E.; Anajafi, E.: International Conference on Chemical, Food and Environment Engineering (ICCFEE'15), Dubai (UAE), Jan. 11-12, 2015.
- [7] Peterson, J.; Cooper, H.; Baukal, C.: Hydrocarbon processing, 2007, 111-115.
- [8] Wikipedia, The Free Encyclopedia, Gas flare, Oct. 25, 2012. Available at:  
[http://en.wikipedia.org/wiki/Gas\\_flare](http://en.wikipedia.org/wiki/Gas_flare)
- [9] Gzar, H.A.; Kseer, K.M.: Journal of Al-Nahrain University, 2009, 12(4), 38-57.
- [10] Duck, B.: Hydrocarbon World, 2011, 6(1), 42-45.
- [11] SENES Consultants Limited. Retrieved Oct. 13, 2012, 25 from The Science and Community Environmental Knowledge (SCEK), (May 2007). Available at:  
[http://scek.ca/documents/scek/Final\\_Reports/RA%202006-08%20Sour%20Gas%20Final%20Report-May%2017\\_%202007.pdf](http://scek.ca/documents/scek/Final_Reports/RA%202006-08%20Sour%20Gas%20Final%20Report-May%2017_%202007.pdf)
- [12] United States Environmental Protection Agency, Industrial Flares, Retrieved Oct. 13, 2012, from United States Environmental Protection Agency. (Sep. 1991). Available at: <http://www.epa.gov/ttn/chief/ap42/ch13/final/c13s05.pdf>
- [13] Johnson, M.R.; Coderre, A.R.: Canada, International Journal of Greenhouse Gas Control. 2012, 8, 121-131.
- [14] AndalibMoghadam, S.H.: 1<sup>st</sup> Professional Iranian environmental conference, Environmental department of Tehran University, Tehran, Iran. 2007, 51, 76-82.
- [15] Abdulhakeem S.O.; Chinevu, A.: SPE-170211-MS, 2014, Sep. 15-17.
- [16] Rahimpour, M.R.; Jokar, S.M.: Journal of Hazardous Materials, 2012, 204-217.
- [17] Manshaa, M.; Saleemia, A.R.; Javeda, S.H.; Ghaourib, B.M.: J. Nat. Gas Chem., 2010, 19(5), 539-547.
- [18] Wilk, M.; Magdziarz, A.: Polish J. of Environ. Stud., 2010, 19(6), 1331-1336.

- [19] Ezersky, A.; Lips, H.: Characterisation of refinery flare emissions: assumptions, assertions and AP-42, Bay Area Air Quality Management District (BAAQMD), 2003.
- [20] Mohanty, C.R.; Adapalaa, S.; Meikap, B.C.: *J. Hazard. Mater.*, 2009, 165, 427-434.
- [21] Mochida, I.; Koraia, Y.; Shirahama, M.; Kawano, S.; Hada, T.; Seo, Y.; Yoshikawa, M.; Yasutake, A.: *Carbon*, 2000, 38, 227-239.
- [22] Ezersky, A.; Guy, B.: Proposed regulation 12, Rule 11: Flare monitoring at petroleum refineries. 2003.
- [23] Global Gas Flaring Reduction Partnership (GGFR) and the World Bank, Guidelines on flare and vent measurement, 700, 900-6 Avenue S.W. Calgary, Alberta, T2P 3K2 Canada, (Sep. 2008).
- [24] McMahon, M.: Estimating the atmospheric emission from elevated flares. BP Amoco Suburbury Report, 1994.
- [25] EPA, Office of Air and Radiation. AP 42, 5<sup>th</sup> ed. Compilation of Air Pollutant Emission Factors. Volume 1: Stationary Point and Area Sources, CH 13: Miscellaneous Sources, 1995.
- [26] Leahey, D.M.; Preston, K.; Strosher, M.: *J. Air Waste Manag. Assoc.*, 2001, 51, 1610-1616.
- [27] Strosher, M.T.: *J. Air Waste Manag. Assoc.*, 2000, 50(10), 1723-1733.
- [28] U.S, EPA, Emission standards division, Control Technologies, Vol. 1B, November 1992.
- [29] EPA, EPA Enforcement targets flaring efficiency violations. Enforcement Alert, 10 (5), Aug. 2012. EPA 325-F-012-002.
- [30] Kinzhikov, A.; Poussenkova, N.: Russian associated gas utilization: problems and prospects. World Wildlife Federation-Russia- Institute of World Economy and International Relations. 2009.
- [31] GAO, Natural gas flaring and venting: opportunities to improve data and reduce emissions. Retrieved Nov. 1, 2012, from U.S. Government Accountability Office, (2004, July). Available at: <http://www.gao.gov/assets/250/243433.pdf>.
- [32] Gulaga, C.: Flare measurement—A Global Perspective. (March 2, 2014). Available at: <http://imeccorp.ca/blog/flare-measurement-a-global-perspective-part-1/>
- [33] Rao, R.S.; Krishna, K.V.S.G. M.; Subrahmanyam, A.: *International Journal of Research in Engineering and Technology*, 2014, 3(16), 23-26.
- [34] Olin, M.J.: A Sierra whitepaper. Flare gas mass flow metering innovations promise more economical choices. 2014. Available at: <http://www.controlglobal.com/assets/14WPpdf/140311-Sierra-FlareGas.pdf>.
- [35] World Bank Group, Initiative to reduce global gas flaring. Sep. 2014. Available at: <http://www.worldbank.org/en/news/feature/2014/09/22/initiative-to-reduce-global-gas-flaring>.
- [36] Norwegian Petroleum Directorate. Regulations to measurement of fuel and flare gas for calculation of CO<sub>2</sub> tax in the petroleum activities. Aug. 1993. ISBN 82-7257-395-4
- [37] Alberta Energy and Utilities Board, Guide 60. TBA, 2005.
- [38] Canadian Association of Petroleum Producers (CAPP) by Clearstone Engineering Ltd., (May 2002), Estimation of flaring and venting volumes from upstream oil and gas facilities, Review by July 2005. Available at: <http://www.oilandgasbmps.org/docs/GEN23-hniquestomeasureupstreamflaringandventing.pdf>
- [39] BC Oil & Gas Commission. Flaring and venting reduction guideline. Version 4.4, April 2015. Available at: <http://www.bcogc.ca/node/5916/download>
- [40] Alberta Energy and Utilities Board. Directive 017: Measurement requirements for upstream oil and gas operations. Feb. 1, 2005.
- [41] Global Gas Flaring Reduction. Monitoring & reporting guidelines for flare reduction CDM projects. Oil & Gas CDM/JI Methodology Workgroup. Sep. 2010. Available at: [http://siteresources.worldbank.org/EXTGGFR/Resources/Monitoring\\_Reporting\\_Guidelines.pdf](http://siteresources.worldbank.org/EXTGGFR/Resources/Monitoring_Reporting_Guidelines.pdf)

- [42] DeLee, J.: Flare gas flow measurement and control. Available at: [www.FluidComponents.com](http://www.FluidComponents.com).
- [43] Matson, J.; Sui, L.; Nguyen, T.H.: 28<sup>th</sup> International North Sea Flow Measurement Workshop, Oct. 26-29. (p 132), 2010.
- [44] Belock, D.: PROCESS. Worldwide 3-2006, 18-19. Available at: <http://www.gemcs.com/download/co2-flow/PROCWW.pdf>.
- [45] World Bank, A voluntary standard for global gas flaring and venting reduction, Washington, DC, 2004. Available at: <http://go.worldbank.org/V3LNYRPOR0>.
- [46] Norwegian Petroleum Directorate, Environmental and Climate Considerations in the Norwegian Petroleum Sector, 2003. Retrieved Aug. 1, 2014. available at: <http://www.npd.no/en/Publications/Facts/Facts-2013/Chapter-9/>.
- [47] Seeley, R.: Oil & Gas Journal, 2014. Available at: <http://www.ogj.com/articles/2014/07/north-dakota-gives-teeth-toflaring-reduction-plan.html>.
- [48] CDM Rulebook, Certified Emission Reductions, available at: <http://www.cdmrulebook.org/304>.
- [49] Rahimpour, M.R.; Jamshidnejad, Z.; Jokar, S.M.; Karimi, G.; Ghorbani, A.; Mohammadi, A.H.: J. of Natural Gas Science and Engineering, 2012, 4, 17-28.
- [50] Mourad, D.; Ghazi, O.; Noureddine, B.: Korean J. Chem. Eng., 2009, 26(6), 1706-1716.
- [51] Dong, L.; Wei, S.; Tan, S.; Zhang, H.: Petroleum Science, 2008, 5(4), 388-394.
- [52] Bachu, S.; Gunter, W.D.: In: Proceedings of the 7<sup>th</sup> International Conference on Greenhouse Gas Control Technologies, 2005, 443-448.
- [53] Wong, S.; Keith, D.; Wichert, E.; Gunter, B.; Mccann, T.: In: Proceedings of the 6th International Conference on Greenhouse Gas Control Technologies, Kyoto, Japan, 2003, 1661-1664.
- [54] California Oil Producers Electric Cooperative, Offgases project oil-field flare gas electricity systems, California Energy Commission Public Interest Energy Research Program, 2008. Available at: <http://www.energy.ca.gov/2008publications/CEC-500-2008-084/CEC-500-2008-084.PDF>.
- [55] Bjorndalen, N.; Mustafiz, S.; Rahman, M.H.; Islam, M.R.: Energy Sources, 2005, 27, 371-380.
- [56] World Bank, Gas flaring reduction projects: Framework for Clean Development Mechanism (CDM) Baseline Methodologies, World Bank. Report number: 6, 2005.
- [57] Christiansen, A.: Clim. Policy, 2001, 1(4), 499-515.
- [58] Statoil awarded IOR prize. Retrieved Nov. 3, 2012, from Statoil. available at: [http://www.statoil.com/en/NewsAndMedia/News/2012/Pages/28aug\\_ior.aspx](http://www.statoil.com/en/NewsAndMedia/News/2012/Pages/28aug_ior.aspx).
- [59] Bawazir, I.; Raja, M.; Abdemohsen, I.: 2014, IPTC-17273-MS.
- [60] Ibitoye, F.I.: Journal of Sustainable Development, 2014, 7(3), 13-22.
- [61] Al-Blaies, W.: 7<sup>th</sup> gas Arabia Summit, Muscat, Oman, 2011, 11-14 Dec.
- [62] Byers, L.; Wessel, H.M.; Kalelova, A.; Korsyus, A.; Tulegenova, G.; Subkhankulova, A.; Zhilkaidrova, A.: 2014, SPE-171186-MS.
- [63] TCO, Poster-Operational excellence (OE) forum-Tengizchevroil (TCO) excellence in flaring reduction, 2014.
- [64] Zadakbar, O.; Vatani, A.; Karimpour, K.: (2008), Oil & Gas Science and Technology - Rev. IFP, 2008, 63(6), 705-711.
- [65] Johnson, M.R.; Coderre, A.R.: J. Air Waste Manag. Assoc., 2011, 61(2), 190-200.
- [66] Tahouni, N.; Gholami, M.; Panjeshahi, M.H.: International Journal of Chemical, Nuclear, Materials and Metallurgical Engineering, 2014, 8(9), 900-904.
- [67] Fisher, P.; Brennan, D.: Hydrocarbon Processing, 2002, 83-85.
- [68] Blanton, R.E.: Presented at the National Petroleum Refiners Association Environmental Conference, San Antonio, Sep. 21, 2010. Available at: <http://www.johnzink.com/wp-content/uploads/NPRA-2010-Environmental-Conference-Paper.pdf>
- [69] Blackwell, B.; Leagas, T.; Seefeldt, G.: Hydrocarbon Engineering, Jan. 2015.

- [70] Younessi, S.; Omidkhah, M.; Tarighaleslami, A.: (2010), The 17<sup>th</sup> Regional Symposium on Chemical Engineering (RSCE), Nov. 1, 2010.
- [71] Saadwai, H.: SPE-166133-MS, 2013.
- [72] Aly, M. E.; Abdelaleem, G.; Emam, E. A.; Gad, F.K.: Transactions of the Egypt. Soc. of Chem. Eng. (TESCE), 2010, 36(4).
- [73] Iandoli, L.; Kjelstrup, S.: Energy Fuels, 2007, 21, 2317-2324.
- [74] Wood, D.A.; Nwaoha, C.; Towler, B.F.: J. of Natural Gas Science and Engineering, 2012, 9, 196-208.
- [75] Takayuki, T.; Kenji, Y.: Energy Policy, 2008, 36, 2773-2784.
- [76] Shahhosseini, Sh.; Alinia, S.; Irani, M.: World Academy of Science, Engineering and Technology, 2009, 3, 12-24.
- [77] Dry, M.E.: Catalysis Today, 2002, 71, 227-241.
- [78] Rahmim, I.I.: presented at the 26<sup>th</sup> IAEE Annual International Conference, Prague, June, 2003.
- [79] Velocys, Inc., Gas-to-liquids conversion of associated gas enabled by microchannel technology, 2009.
- [80] Larson, E.D.; Jin, H.; Celi, F.E.: Large-scale gasification-based co-production of fuels and electricity from Switchgrass", 2009. Available at: <http://www.princeton.edu/pei/energy/publications/texts/RBAEF-Thermochem-fuels-power-BioFPR-Mar2009-supporting-info.pdf>
- [81] Oguejiofor, G.C.: Energy Sources, Part A, 2006, 28, 1365-1376.
- [82] Tolulope, A.O.: Environ. Inform. Arch., 2004, 2, 387-393.
- [83] NNPC (Nigerian National Petroleum Corporation), Annual statistical bulletin, 2009. Available at: [www.nnpcgroup.com](http://www.nnpcgroup.com)
- [84] Pederstad, A.; Gallardo, M.; Saunier, S.: Improving utilization of associated gas in US tight oil fields, Carbon Limits, April 2015, Registration/VAT no.: NO 988 457 930. Available at: [http://catf.us/resources/publications/files/Flaring\\_Report\\_Appendix.pdf](http://catf.us/resources/publications/files/Flaring_Report_Appendix.pdf).
- [85] Weimer, A.: Small-scale gas-to-liquids for flare gas (NanoCatalystGTL), Technology Application for Cleantech to Market (C2M), 2015. Available at: [https://ei.haas.berkeley.edu/education/c2m/docs/Fast%20utomated%20energy%20audits%20of%20commercial%20buildings\\_Application.pdf](https://ei.haas.berkeley.edu/education/c2m/docs/Fast%20utomated%20energy%20audits%20of%20commercial%20buildings_Application.pdf).
- [86] Oxford Catalyst Group, Microchannel gas-to-liquids for monetizing associated and stranded gas reserves, 2011.
- [87] Branco, D.A.C.; Szklo, A.S.; Schaeffer, R.: Energy, 2010, 35, 158-167.
- [88] Knutsen, K.T.: Modelling and optimization of a gas-to-liquid plant, Norwegian University of Science and Technology, 2013. available at: <http://www.diva-portal.org/smash/get/diva2:648742/FULLTEXT01.pdf>.
- [89] Rahimpour, M.R.; Mirvakili, A.; Paymooni, K.; Moghtaderi, B.: J. of Natural Gas Science and Engineering, 2011, 3, 484-495.
- [90] Razak, A.M.Y.: Industrial gas turbines: performance and operability, Woodhead Publishing Limited, Cambridge, England, 2007.
- [91] Combined Heat and Power Partnership, Waste heat to power systems, 2012. available at: [http://www.epa.gov/chp/documents/waste\\_heat\\_power.pdf](http://www.epa.gov/chp/documents/waste_heat_power.pdf).
- [92] Bott, R.D.: Flaring answers + questions, Retrieved Oct. 20, 2012, from Stuff Connections - World Bank Intranet, 2007. Available at: <http://siteresources.worldbank.org/EXTGGFR/Resources/578068-1258067586081/FlaringQA.pdf>.
- [93] Heydari, M.; Abdollahi, M.A.; Ataei, A.; Rahdar, M.H.: International Conference on Chemical, Civil and Environmental Engineering (CCEE) June 5-6, Istanbul (Turkey), 2015.
- [94] Farina, M.F.: GE Energy, Global Strategy and Planning, Flare Gas Reduction, Jan. 2011. Available at: [http://www.ge-spark.com/spark/resources/whitepapers/Flare\\_Gas\\_Reduction.pdf](http://www.ge-spark.com/spark/resources/whitepapers/Flare_Gas_Reduction.pdf).

- [95] Petruzzi, L.; Cocchi, S.; Fineschi, F.: *J. Power Sources*, 2003, 118, 96-107.
- [96] Stambouli, A.B.; Traversa, E.: *Renew. Sustain. Energy Rev.*, 2002, 6, 433-455.
- [97] Yuan, J.; Sunden, B.: *Trans. ASME J. Heat Transf.*, 2005, 127, 1380-1390.
- [98] Saidi, M.; Siavashi, F.; Rahimpour, M.R.: *J. of Natural Gas Science and Engineering*, 2014, 17, 13-25.
- [99] Energy efficient cities initiative, Good practices in city energy efficiency: Tianjin, China - landfill gas capture for electricity generation, 2009. Available at: [https://www.esmap.org/sites/esmap.org/files/Tianjin\\_Case\\_Study\\_033011\\_coverpage.pdf](https://www.esmap.org/sites/esmap.org/files/Tianjin_Case_Study_033011_coverpage.pdf).
- [100] Xu, Q.; Yang, X.; Liu, C.; Li, K.; Lou, H.H.; Gossage, J.L.: *Ind. Eng. Chem. Res.*, 2009, 48, 3505-3512.
- [101] Maung, T.; Ripplinger, D.; McKee, G.; Saxowsky, D.: Economics of using flared vs. conventional natural gas to produce nitrogen fertilizer: A feasibility analysis, North Dakota State University, 2012. Available at: <http://agecon.lib.umn.edu/>.
- [102] Muyzer, G.; Sorokin, D.; Stams, F.; Siezen, R.: Why sequence bacteria that reduce sulfur compounds?, Retrieved Oct. 14, 2012, from Doe Joint Genome Institute, 2012. Available at: <http://www.jgi.doe.gov/sequencing/why/100322.html>
- [103] Fomina, M.: SPE-172336-MS, 2014.
- [104] Brant, B.; Brueske, S.: *Oil Gas J.*, 1998, 96(20), 61-65.