

PHYSICS & SOCIETY

A Publication of The Forum on Physics and Society • A Forum of The American Physical Society

EDITOR'S COMMENTS

Anybody willing to look beyond the point of their nose will recognize that the question of supplying sufficient energy for a growing world, hungry for universal prosperity, without choking that world on the byproducts of the production and use of that energy, is the major problem at the interface be-

tween science and society. A prime, much debated, possible solution to the problem is the wide spread use of nuclear energy. The problems inherent in such a solution are long run resource availability, safety, waste disposal, and the

continued on page 2

IN THIS ISSUE

EDITORS' COMMENTS

FORUM NEWS

- 3 Election Results, *by Marc Sher*
- 3 Project on Elements of an Energy Strategy, *by Tony Nero*

ARTICLES

- 4 The Status of Nuclear Waste Disposal, *by David Bodansky*
- 7 Nuclear Power and Proliferation,
by Gerald E. Marsh and George S. Stanford
- 9 4S (Super Safe, Small and Simple LMR), *by Akio Minato*
- 12 Strawbale Construction — Low Tech vs. High Tech or Just Better Physical Properties? *by Ken Haggard*

LETTERS

- 15 "Intelligent Design" Not Necessarily Religion,
by David Van Domelen
- 15 Worrying About Science vs Religion a Waste of Time?
by Derek Walton
- 15 Physicists Should be Defending Evolution, *by Ronald Mirman*

REVIEWS

- 16 Twilight in the Desert: The Coming Saudi Oil Shock and the World Economy *by Matthew Simmons, reviewed by Albert A. Bartlett*
- 17 The End of Oil: On the Edge of a Perilous New World
by Paul Roberts
- 17 The Hydrogen Economy: The Creation of the Worldwide Energy Web and the Redistribution of Power on Earth *by Jeremy Rifkin, both reviewed by John L. Roeder*
- 18 Catastrophe: Risk and Response *by Richard A. Posner, reviewed by Brian H. Nordstrom*

IN THE OCTOBER WEB ISSUE

ELECTIONS

Candidate Statements. *Please Vote!*
Vote via the Web at: <http://physics.wm.edu/ballot.html>. *Please Vote!*

EDITOR'S COMMENTS

ARTICLES

Introduction to a Sequence of Articles in Physics & Society on Science Input to Government, *W.K.H. Panofsky*
Scientific Integrity in Government and Ballistic Missile Defense,
Edwin E. Salpeter
Physics in Theater, *Harry Lustig*
The Great Fallout-Cancer Story of 1978 and its Aftermath,
Daniel W. Miles
The Genius as National Icon: Albert Einstein, Zionism and Social Responsibility, *Zeev Rosenkranz*

LETTERS

Intelligent Designer Inconsistency with Science's Foundations,
Alan D. Franklin
Letter to Emily, *Max Sherman*
Response to "The Role of Faith," *Stephen Rosenblum*
Physicist's Addition to the Bible, *Art S. Jensen*
Re: Commentary in Jan. 2005, P&S, *Ronald Mirman*
UCS and Nuclear Power, *Kurt Gottfried*

NEWS

Politics and Science
Holt, Scientific Societies Oppose Teaching Intelligent Design as Science

REVIEWS

The Future of Life, Edward O. Wilson, *reviewed by John L. Roeder*
J. Robert Oppenheimer: And the American Century, David Cassidy,
reviewed by Gary Prézeau

Physics and Society is the quarterly of the Forum on Physics and Society, a division of the American Physical Society. It presents letters, commentary, book reviews and reviewed articles on the relations of physics and the physics community to government and society. It also carries news of the Forum and provides a medium for Forum members to exchange ideas. Opinions expressed are those of the authors alone and do not necessarily reflect the views of the APS or of the Forum. Contributed articles (up to 2500 words, technicalities are encouraged), letters (500 words), commentary (1000 words), reviews (1000 words) and brief news articles are welcome. Send them to the relevant editor by e-mail (preferred) or regular mail.

Co-Editors: Al Saperstein, Physics Dept., Wayne State University, Detroit, MI 48202, ams@physics.wayne.edu; Jeff Marque, Senior Staff Physicist at Beckman Coulter Corporation, 1050 Page Mill Rd., MSY-14, Palo Alto, CA 94304, jjmarque@gte.net. **Reviews Editor:** Art Hobson, ahobson@comp.uark.edu. **Electronic Media Editor:** Andrew Post-Zwicker, azwicker@pppl.gov. **Layout at APS:** Leanne Poteet, poteet@aps.org. **Web Manager for APS:** Sara Conners, conners@aps.org. ***Physics and Society* and be found on the Web at <http://www.aps.org/units/fps>.**

Editor's Comments continued

potential for nuclear weapons proliferation. This journal has published science-policy discussions of these issues from different viewpoints, in the past, and will continue to do so in the foreseeable future. This issue contains three articles on aspects of nuclear energy supply and one article on a method of building construction intended to minimize the need for energy and pollution. The books reviewed in this issue also address the needs and risks of alternative energy paradigms. We hope our readers will find these contributions to the energy debate useful and will, themselves, contribute further to the necessary public and professional debate in future pages of this journal.

In as much as a scientific outlook on the world around us is a necessary part of any solutions to our pressing energy and environmental problem, the letters in this issue — addressing the relation between science and religion in our society — are also addressing the same problem. If, because of a perceived conflict between science and religion, American society drifts away from a scientific, evidence-based, problem-solving mode of thought and action in public affairs, no solutions, nuclear or otherwise, will be found to the problem. Hopefully, our readers — as leaders in science and the community — will recognize the necessary interrelation between these two, apparently very different issues, one abstractly philosophical, the other very practical, and become involved in helping to productively shape our future society. — *AMS*

Reference 3 of David Bodansky's article in this issue, "The Status of Nuclear Waste Disposal," refers to an article in our July 2004 issue by William Hannum, Gerald Marsh, and and George Stanford called "Purex and Pyro Are Not the Same." We call the reader's attention to a subsequent point/counterpoint style set of articles in our *January 2005* issue by Richard Garwin and Hannum *et. al.* Regarding our announcement in the October 2005 issue about a series of articles on science advice, don't give up on us! One of us (JJM) concedes defeat on the possibility of obtaining such an article for this issue, but I'm working hard for subsequent issues. — *JJM*

FORUM NEWS

Election Results

Marc Sher

To FPS people: The election is over and the results are clear (the closest race has a margin over 90 votes). Congratulations to the winners:

Vice-Chair: Lawrence Krauss

Executive Committee: Barbara Levi, Pete Zimmerman

FPS Rep. to POPA: Ruth Howes

The turnout was the largest in over a decade. There were 908 votes cast (over 20% of our membership), there were no problems with duplicate votes (due to the new software), and no complaints from anyone.

Marc Sher
Forum Elections Coordinator
mtsher@wm.edu

Project on Elements of an Energy Strategy

Anthony Nero

Considering the importance of implementing a more effective energy strategy for the near and long term, a session of invited papers is being organized by the Forum for the April 2006 meeting in Dallas on “elements of a near-term energy-strategy.” This session will examine technologies that could contribute within the next 2 decades to a U.S. energy system that is improved with respect to oil security and environmental impacts. Such technologies might, for example, include hybrid cars among energy end uses and improved photovoltaic systems and nuclear power plants for energy production. This session is scheduled for 1:30 PM the last day of the meeting, Tuesday, April 25. There will also be an invited session on new types of climate change technologies at 10:45 that morning.

As a broader effort, FPS is examining how to proceed with a project utilizing the FPS Discussion Board, which has been inactive for more than a year, to provide information on energy technologies for both the near and longer term - the latter taken to be the first half of the 21st century. FPS members and others will be invited to help develop this information, as represented largely by key reports available in the literature or on web sites, which would be available as citations, links, or otherwise on the information side of the fpsboard web site.

The FPS Board itself could then be used for discussion of whatever aspects of these technologies and their use might be of interest to APS members. Furthermore, for small groups who wish to focus together on specific topics on energy technologies, the FPS Board can support private forums for discussion and joint work. We anticipate that the FPS Board site, at www.fpsboard.org, will be reorganized for these purposes beginning in January.

At the April meeting, most of the FPS business meeting on the afternoon of Monday, April 24, will be devoted to this project, so that those who are interested may wish to plan on being at this meeting, as well as attending the invited sessions on Tuesday. The business meeting will occur right after the Forum awards session.

Anthony Nero
Indoor Environment Dept., Environmental Energy Technologies Div.
Bldg 90 - Rm 3058, Lawrence Berkeley N Lab
Univ. of California, Berkeley CA 94720
phone 510-486-6377 fax 510-486-6658 email avnero@lbl.gov

ARTICLES

The Status of Nuclear Waste Disposal

David Bodansky

A. Introduction

Nuclear waste disposal is now perhaps the most visible problem facing the nuclear power enterprise, and it has become a cliché to refer to the wastes as nuclear power's Achilles' heel. In this paper, after briefly describing the nature of the wastes and options for their disposal, we will explore the current status of waste disposal plans and the associated controversies, with special reference to the proposed Yucca Mountain repository.¹

B. The wastes and stages in their handling

The fuel in all U.S. power reactors and the large majority worldwide consists of solid pellets of uranium oxide, enclosed in thousands of long cylindrical fuel rods. One-third of the fuel is removed at intervals of about 18 months. Unless this spent fuel is reprocessed, it becomes the waste, remaining in this solid form throughout all subsequent transfer and storage. During the past decade, the 103 operating U.S. reactors have annually discharged something in the rough neighborhood of 2000 tonnes of fuel. By about 2010, the cumulative discharges will reach the planned Yucca Mountain capacity of 63,000 tonnes of commercial spent fuel.

The spent fuel's activity at first drops precipitously with time, due to the relatively short half-lives of most of the radioactive fission products, and then drops somewhat more gradually as the actinides decay.² After one year the reduction factor, compared to the activity when the reactor is turned off, is about 75. It is roughly 400 after 10 years, 50,000 after 500 years, 400,000 after 10,000 years, and 3,000,000 after 100,000 years.

The first stage of waste handling is at the reactor site, where the spent fuel is initially put into a water-filled cooling pool. In an increasing number of cases, as these pools fill up the older fuel is transferred into air-cooled casks that remain at the reactor site. These can suffice for many decades of storage, but keeping the wastes on-site is considered a short-term measure. Some countries (Sweden and Switzerland) have already instituted a second stage, namely "interim" storage at a centralized location. There is no such facility in the United States. An ongoing effort by a utility consortium to establish one on Indian land in Utah has received Nuclear Regulatory Commission (NRC) approval, but is opposed by Utah officials.

Whether interim storage is implemented or bypassed, current planning throughout the world is for eventual storage in underground mined repositories, although as yet only the United States and Finland have identified specific locations.

A basic decision is whether or not to reprocess the spent fuel. The most ambitious reprocessing proposals call for extracting all actinides from the spent fuel and returning them to a fast reactor where they are "burned up," primarily in fission. This is the goal of *pyroprocessing*, currently under development. A less ambitious approach, in which only plutonium and uranium are removed, has been

used for spent fuel from commercial reactors in France, the United Kingdom, and Russia, as well as for plutonium weapons programs. The remaining radioactive residues then become the wastes.

The United States decided in the 1970s against commercial reprocessing, primarily out of concern that separated plutonium might be diverted by terrorists or used by governments elsewhere to inaugurate nuclear weapons programs. Further, with uranium in ample supply it was less expensive to dispose directly of the spent fuel. However, Congress in November 2005 moved to appropriate funds for the development of technologies to recycle existing spent fuel—an initiative that, if pursued, may lead to major changes in the U.S. waste disposal program and revive proliferation concerns.

For the longer term, a breeder reactor economy may become desirable if a proliferation-resistant fuel cycle can be implemented. Pyroprocessing, with co-located facilities, here offers the most promise.³ Its successful development would limit proliferation dangers and change the "long-term" waste problem into a 500-year problem, because without the actinides relatively little activity remains after 500 years. It would also make uranium resources quasi-infinite, by increasing one-hundredfold the energy extracted from a given uranium deposit and at least another hundredfold by making dilute uranium sources, such as seawater, affordable. Just such a solution is contemplated in some DOE planning, using yet-to-be-built new reactors—the so-called Generation IV reactors.

C. The U.S. solution: Yucca Mountain

After decades of national indecision, Congress in 1987 designated Yucca Mountain, Nevada as the sole site for study as a possible waste disposal site. Yucca Mountain is about 160 km northwest of Las Vegas, in a sparsely populated, dry desert region. The repository is to be situated several hundred meters below ground and about 300 m above the water table. It is to be honeycombed with tunnels, into which "waste packages" would be moved on permanent rail tracks. In current planning, each waste package would be a double-walled corrosion-resistant container holding about 8 or 9 tonnes of fuel. The dry environment and the surrounding geological formations limit the flow of water into the repository and impede the outward movement of any radionuclides that escape if the waste package is breached.

Although design of the repository has long been underway, the detailed plan is still being modified. Thus, on October 25, 2005 the DOE specified that spent fuel is to be shipped in standardized canisters that would not have to be opened at Yucca Mountain, making fuel handling there simpler and "cleaner."

Radiation protection standards for nuclear waste repositories were promulgated by the Environmental Protection Agency (EPA) in 1985, but key parts were thrown out in 1987 by a U.S. Appeals Court for adjudged inconsistencies. Congress in 1992 then asked the National Academy of Sciences (NAS) to recommend "reasonable standards" for a Yucca Mountain repository and instructed

the EPA to establish standards “based on and consistent with” the NAS recommendations. The most striking of the resulting recommendations was that the regulatory horizon continue for the period of geologic stability, taken to be about 10^6 years, rather than stop after the previously prevailing 10^4 years.⁴

The EPA responded with new “final” standards in 2001. These set a dose limit of 15 mrem/yr for the “reasonably maximally exposed individual” (RMEI) living in the neighborhood of Yucca Mountain. The standard was to be in effect for 10^4 years. Although the EPA presented justifications for departing from the million-year recommendation, another Appeals Court in 2004 ruled that this departure violated Congress’s instructions.

The EPA’s proposed solution has been to retain the dose limit of 15 mrem/yr for the first 10,000 years and establish a new limit of 350 mrem/yr for the next 990,000 years.^{5,6} In partial explanation, the EPA compared the “protected” RMEI to today’s residents of Colorado. It estimated the average natural background dose to be 350 mrem/yr near Yucca Mountain and 700 mrem/yr in Colorado [Ref. 5, p. 49037]. The addition of 350 mrem/yr from Yucca Mountain wastes would raise the RMEI’s calculated total dose to 700 mrem/yr, the mean dose in Colorado today. The EPA’s next steps are to review comments, make revisions, and then issue a final rule, presumably in 2006.

D. Calculated Yucca Mountain performance

The performance of the Yucca Mountain repository relies largely on decay and delay. Decay steadily reduces the radioactive inventory. The radionuclides are delayed in reaching the biosphere because little water enters the repository, the multi-layer waste package protects the spent fuel, and most radionuclides that eventually escape move only slowly through the ground. For example, plutonium is probably retarded by more than a factor of 100 (compared to the water itself) due to temporary attachment to the rock through which it travels [Ref. 1, p. 270].

The overall effectiveness of the design has been analyzed by the Department of Energy (DOE) in a series of Total System Performance Assessments (TSPAs), which use Monte Carlo techniques to calculate anticipated radiation doses for the RMEI. In the last TSPA reported before the DOE made its recommendation to construct the repository, the mean calculated dose for the RMEI was under 2×10^{-5} mrem/yr for the first 10,000 years.⁷ This is far below the EPA limit of 15 mrem/yr.

The calculated doses rise subsequently, as the waste packages gradually deteriorate and escaping radionuclides travel to the accessible environment. The mean calculated dose reaches about 0.1 mrem/yr after 100,000 years and a maximum of roughly 100 mrem/yr after 400,000 years, followed by a slow decline. While far in excess of the 10,000-year standard, this dose lies below the proposed long-term limit of 350 mrem/yr.

Although the TSPA results emerge from extensive calculations they probably represent only rough guides, because the times involved are far beyond those of human experience, and many uncertainties exist in the models. The DOE’s successive TSPAs have differed substantially, and future TSPAs can be expected to differ further, especially if waste handling plans are significantly changed.⁸ A parallel TSPA effort, carried out by the industry-spon-

sored Electric Power Research Institute (EPRI) found lower doses than did the DOE at 100,000 years and beyond.

The DOE and independent outside groups, especially the Nuclear Waste Technical Review Board (NWTRB), have highlighted areas that need further investigation. These include:

- a. Volcanism (not included in the calculations described above). The annual probability of the repository being impacted by a volcanic event has been estimated by a DOE panel to be 1.6×10^{-8} and by the NRC to be up to 1×10^{-7} . High doses could be produced if molten rock flows through a waste package and carries radioactive material into the atmosphere. Considering both likelihood and consequences, the DOE concluded that the “probability-weighted dose” is less than 0.2 mrem/yr at all times, but the DOE and NRC positions are not yet reconciled.
- b. Waste canister corrosion. The DOE has allayed NWTRB concerns about some corrosion mechanisms, but questions exist about additional mechanisms.
- c. Water infiltration. Observations in 1996 found that ^{36}Cl from nuclear weapons tests had reached the repository, suggesting that water flow from the surface was faster than originally anticipated. Other groups have not confirmed these observations, and their validity is in question.
- d. Radionuclide transport. A better understanding is needed of the rate of radionuclide movement from the repository to the biosphere, including the accelerated rates that might result if radionuclides become attached to small particles (colloids) or can find extensive pathways through fractures in the rock.

To date, the DOE has tended to address uncertainties by making conservative (pessimistic) assumptions. Revised TSPA calculations, with up-dated assumptions, will be used for the DOE’s forthcoming application to the NRC for a construction license. However, the DOE reports that it is now “unable to estimate realistically when the license application will be submitted” pending incorporation of the October 2005 changes into its overall design.⁹ For its review, the NRC will carry out independent analyses, including its own TSPA. Assuming NRC approval is granted and the repository is built, a further NRC license will be required before the repository is opened to receive wastes.

E. Intergenerational responsibility

An obligation towards future generations is universally acknowledged, but there is little agreement as to the nature of this obligation. One view is that worrying about people 10,000 years hence is excessive and that concern for one million years is absurd. An alternative view is that our responsibilities persist undiminished for the indefinite future. These differences do not yield to analytic discussion, and in practice are resolved by the perforce arbitrary setting of standards.

The standards proposed by the EPA reflect aspects of both views. Thus, the EPA has set stringent standards that remain constant for the first 10,000 years, while its proposed dose limit for later times is much less demanding. As a corollary provision, the EPA specifically rejects the projection of “increases or decreases of human knowledge or technology” [Ref. 5, p. 49063].

In an extensive discussion in the Federal Register, the EPA indicated that it did not want to “unreasonably constrain the current and succeeding generations’ abilities to pursue achievable solutions they deem best suited to meet the interests of all generations,” as might happen if the dose limit for the far future was too restrictive [Ref. 5, p. 49040]. It also wanted to protect distant generations from radiation exposures that “pose a realistic threat of irreversible harm or catastrophic consequences” [Ref. 5, p. 49038]. The proposed 350 mrem/yr standard serves both goals, in that it probably can be met and the resulting total dose is below the natural radiation dose experienced by many people today.

A modest formulation of intergenerational equity is encapsulated in the guideline: “Each generation should strive to pass on to immediately succeeding generations an improved world, including the potential to sustain such improvements for the indefinite future.”¹⁰ This guideline points to the need to consider the near-term consequences of rejecting the Yucca Mountain repository along with the consequences of developing it. The abandonment of the repository would be a serious setback for nuclear power — even if other waste disposal solutions might suffice from a technical standpoint—making it all the harder to cope with the problems of global climate change and of limited oil and gas supplies.¹¹ The dangers these problems pose for people in this century and the next appear to be much greater in magnitude than the more distant dangers from Yucca Mountain, and addressing them deserves a high priority in any weighing of intergenerational responsibilities.

F. The road ahead

Recent steps in the Yucca Mountain process at first went as anticipated. The DOE in early 2002 recommended proceeding with the repository, the President approved, the Governor of Nevada objected, and Congress overrode the objection. The further schedule called for a DOE application in 2004 to the NRC for a construction license, to be followed by a three-year NRC review. Assuming NRC approval, waste deliveries were to begin in 2010 and continue until 2033. The repository is to be monitored and kept open for changes, including waste retrieval, for fifty to several hundred years after the first deliveries.

This schedule was disrupted by delays in the DOE’s preparation of its license application and the court decision in July 2004 that required new EPA standards. But, if there are no radical shifts in DOE policies, it seems reasonable to surmise that within the next several years the EPA will present its final standards, the DOE will find that the repository meets them and will apply for a construction license, and the NRC will grant it.

However, hurdles will remain from lawsuits and political opposition. Some environmental groups find in nuclear wastes an effective weapon “to drive a final stake in the heart of the nuclear power industry” and are unlikely to give up this weapon.¹² The State of Nevada also seems determined to stop the Yucca Mountain project. In the end, the fate of the project appears more dependent on court decisions and political power than on technical evaluations or broad policy considerations.

If the Yucca Mountain project is defeated, it may be a long time before support can develop for an alternative because any site

is likely to run into similar obstacles. The wastes could be safely retained for many decades in dry storage at the reactor sites or in one or more central interim storage facilities. But this would be viewed as a stop-gap, and the resort to it seen as evidence of a basic and perhaps insurmountable problem with nuclear power.

If the project is approved, and additional reactors are built, the output of spent fuel will increase. Possibilities for the long-term disposal of waste produced after 2010 include expansion of the Yucca Mountain facility, new geologic repositories elsewhere, or burial in deep boreholes.¹³ It may also eventually become feasible to revisit the now taboo option of burial in the clay of the deep seabed. As discussed above, and perhaps influencing the recent congressional actions, the demands upon any waste disposal option would be reduced if a proliferation-resistant reprocessing fuel cycle is developed and implemented.

¹ *The discussion of technical details and developments before 2004 draws from: David Bodansky, Nuclear Energy: Principles, Practices and Prospects, 2nd edition (New York: Springer/AIP Press, 2004).*

² *The actinides are the elements with atomic numbers from 89 through 103; they are formed in reactors by neutron capture and beta decay.*

³ *See, e.g., William H. Hannum, Gerald E. Marsh, and George S. Stanford, “Purex and Pyro are Not the Same,” Physics and Society 33, No. 3, 8-11 (July 2004).*

⁴ *National Research Council, Technical Bases for Yucca Mountain Standards (Washington, D.C.: National Academy Press, 1995).*

⁵ *U.S. EPA, “40 CFR Part 197, Public Health and Environmental Protection Standards for Yucca Mountain, Nevada; Proposed Rule,” Federal Register 70, no. 161, 49014-49065 (August 22, 2005). [Available at: <http://www.epa.gov/radiation/docs/yucca/70fr49013.pdf>]*

⁶ *The 350 mrem/yr limit applies to the median of the calculated Yucca Mountain doses, as discussed in Ref. 5, pp. 49041-49046, while the comparison is made to the mean Colorado dose. The median is less than the mean in typical dose distributions, and its use may relax the demands upon repository performance, but the EPA adopted it to avoid the distortions that could be created by a few extreme estimates.*

⁷ *U.S. DOE, Yucca Mountain Science and Engineering Report Rev. 1, Report DOE/RW-0539-1 (North Las Vegas, NV: U.S. DOE, 2002), Fig. 4-180.*

⁸ *The TSPAs were carried out for the commercial wastes in the form of spent fuel. If some of these wastes are the product of reprocessing (followed by solidification) the results would be changed, presumably in the direction of lower doses.*

⁹ *Michael R. Shebelskie et al, The Department of Energy’s Sixth Monthly Status Report, Docket No. PAPO-00 (Nuclear Regulatory Commission, November 1, 2005).*

¹⁰ *This sentence is taken from Ref. 1, p. 363; see Ref. 1 for references to its antecedents.*

¹¹ *See, e.g., Robert W. Albrecht and David Bodansky, “Oil, CO₂, and the Potential of Nuclear Energy,” Physics and Society 34, No. 1, 12-15 (January 2005).*

¹² *Michael McCloskey, then-chairman of the Sierra Club, as quoted in Luther Carter, Nuclear Imperatives and Public Trust (Washington, D.C.: Resources for the Future, 1987), p. 431; also, Ref. 1, pp. 358-9.*

¹³ *Consideration of the borehole option is urged, for example, in The Future of Nuclear Power, An Interdisciplinary MIT Study (2003). [Available at <http://web.mit.edu/nuclearpower/>]*

—David Bodansky
Department of Physics
University of Washington
bodansky@phys.washington.edu

Nuclear Power and Proliferation

Gerald E. Marsh and George S. Stanford

The day when the United States must join other countries in turning to nuclear power cannot be long delayed. The main reason, as stated by the American Physical Society's study, *Nuclear Power and Proliferation Resistance: Securing Benefits, Limiting Risk*, is that "Global electricity demand is expected to increase by more than 50 percent by 2025. Nuclear power is a primary carbon-free energy source for meeting this extensive global energy expansion." Realistically, the only alternative to nuclear power for such an expansion is coal, and even "clean" coal emissions have a large impact on human health and the environment. In the developing world, as recent history shows, environmental and health concerns come last.

In dealing with the risks of the increased use of nuclear power, the APS study appropriately singles out proliferation. The study maintains that:

"The technologies used in peaceful nuclear power programs overlap with those used in the production of fissionable material for nuclear weapons. . . . Nuclear reactors themselves are not the primary proliferation risk; the principal concern is that countries with the intent to proliferate can covertly use the associated enrichment or reprocessing plants to produce the essential material for a nuclear explosive. Further, poorly secured nuclear materials present a risk of proliferation through theft and transfer to a country or terrorist groups."

We are in full agreement.

The study suggests a number of steps that should be taken, including:

1. Significantly strengthen the federal Technical Safeguards R&D program: increase resources, identify near-term technology goals, formulate a technology roadmap, and improve interagency coordination.
2. Increase the priority of proliferation resistance in design and development of all future nuclear energy systems.
3. Develop & strengthen international collaborations on key proliferation-resistant technologies.
4. Align federal programs to reflect the fact that there is no urgent need to initiate reprocessing or to develop additional spent fuel repositories in the US.

We agree with the first three recommendations, and discuss the fourth below. In general, we feel that the report does not examine the nature of the proliferation problem carefully enough, and the recommendations are too timid to deal with the potential for proliferation.

Today's proliferation fears go back to two portions of the *Non-Proliferation Treaty*, Paragraph 3 of Article III, and Paragraph 1 of Article IV. The first states:

"The safeguards required by this article shall be implemented in a manner designed to comply with Article IV of this Treaty, and to avoid hampering the economic or technological development of the Parties or international cooperation in the field of peaceful nuclear activities, including the international exchange of nuclear

material and equipment for the processing, use or production of nuclear material for peaceful purposes in accordance with the provisions of this article and the principle of safeguarding set forth in the Preamble of the Treaty."

The second emphasizes that

"Nothing in this Treaty shall be interpreted as affecting the inalienable right of all the Parties to the Treaty to develop research, production and use of nuclear energy for peaceful purposes without discrimination and in conformity with articles I and II of this Treaty."

In other words, signatories to the Treaty have the right to develop a full-scale fuel cycle, including the production of nuclear materials and the reprocessing of spent fuel. This is the origin of the proliferation risk singled out by the APS study, and constitutes technological license that is simply no longer tolerable.

The APS study implicitly recognizes the unacceptability of the current nonproliferation regime when it notes that:

"President Bush made a two part proposal to restrict the spread of enrichment and reprocessing technologies: 1) The world's leading nuclear exporters should ensure that states have reliable access at reasonable cost to fuel for civilian reactors, so long as those states renounce enrichment and reprocessing; and 2) The 40 nations of the Nuclear Suppliers Group should refuse to sell enrichment and reprocessing equipment and technologies to any state that does not already possess full-scale, functioning enrichment and reprocessing plants."

The study says, of the Bush proposal,

"Such fuel assurances and pledges to restrict sales are important components of a strategy to reduce the proliferation risks of nuclear power. However, no single diplomatic, military, economic, or technical initiative alone will be able to fully deal with the proliferation challenge."

While we don't disagree with that, we think it diminishes the proposal's importance.

The existence of the "nuclear club" has always implied a two-tiered world composed of the nations that have nuclear weapons, and those that do not. Correcting the proliferation problem means formally freezing this difference in place, while requiring the nuclear club to live up to new international obligations.

While the Bush proposal is fine, as far as it goes, we believe it must be formalized by amending the Nonproliferation Treaty to eliminate the right of each nation to develop its own full-scale fuel cycle. Of course, this could be revisited in the future—and the developing world would surely insist on provision for that sort of review.

In return, the nuclear club needs to formally guarantee fuel services and disposal of the true waste at reasonable prices through an international entity such as the International Energy Agency or the International Atomic Energy Agency. The negotiations will not be easy, even though Article VIII of the Treaty allows any party to the treaty to propose amendments.

Some nations, and many individuals, will raise the mantra of Article VI of the Treaty, which declares:

“Each of the Parties to the Treaty undertakes to pursue negotiations in good faith on the effective measures relating to cessation of the nuclear arms race at an early date and to nuclear disarmament, and on a treaty on general and complete disarmament under strict and effective international control.”

Even those who deeply believe in the goals of that article on moral grounds must realize that its invocation in the past has been primarily for political reasons. When the treaty was negotiated, the “arms race” was between the Soviet Union and the United States. This has certainly ended. “Complete [nuclear] disarmament,” given human nature, is not likely in the foreseeable future—and may not even be desirable, since the end point may be unstable. Realistically, what is important is to minimize the probability of war, and, contrary to popular perception, nuclear weapons may actually enhance stability by making people very, very careful. At least, that is what we must hope.

It is the potential connection between reprocessing and proliferation, along with the deficiencies of the Nonproliferation Treaty, that undoubtedly led the APS study to conclude that the United States should not soon reverse its stance against reprocessing:

“Any decision to reprocess spent fuel in the United States must balance the potential benefits against the proliferation risks. Fortunately, there is no near-term urgency to make a decision on implementing reprocessing in the United States. No foreseeable expansion of nuclear power in the US will make a qualitative change to the need for spent fuel storage over the next few decades. Even though Yucca Mountain may be delayed considerably, interim storage of spent fuel in dry casks, either at current reactor sites, or at a few regional facilities, or at a single national facility, is safe and affordable for a period of at least 50 years.

“Further, any spent fuel that would be emplaced at Yucca Mountain would remain available for reprocessing for many decades. Nuclear Regulatory Commission regulations require that the Yucca Mountain repository, if licensed, remain open and the waste be retrievable for 50 years after emplacement of the waste. In the meantime, the repository would provide excellent protection of spent fuel from terrorist threats, and would be capable of serving as a final disposal solution if that is eventually judged to be appropriate.

“The decision on a second repository—or on whether to reprocess—can therefore be comfortably deferred, and should be deferred, for at least a decade. . . .

“In the longer term, the balance among the benefits, costs, and risks of reprocessing may change significantly. By reprocessing spent fuel and burning the recovered uranium and plutonium in a nuclear “breeder” reactor, it is possible to get as much as 50 times more energy out of the original uranium. Therefore, if nuclear energy expands substantially in the future and puts pressures on the availability of low-cost uranium fuel, then reprocessing and breeder reactors could become the preferred option if the associated proliferation risks can be addressed.”

While most of the above is technically correct, we suggest that those proliferation risks not only can be addressed, but must.

The study misses two points: First, the rest of the world is going its own way whether the United States reprocesses spent fuel or not, so the U.S. decision to reprocess should be based primarily on U.S. interests, not fear that such a decision would promote international proliferation. The past has shown that there is little if any connection between U.S. reprocessing policy and the proliferation of nuclear weapons.

Second, and more important, the APS conclusion that reprocessing can be delayed ignores the political dimension. Recent polls have shown that the primary public concern about nuclear power is the disposal of the used fuel, seen as “waste.” Public fears revolve around the perception that the used fuel must be isolated for more than 10,000 years, and that perception is embodied in regulatory and judicial requirements based on the fact that some of the plutonium and other transuranics produced in reactors have radioactive half-lives in the thousands of years.

If, however, the uranium and transuranics were removed from the waste, only the true waste—the fission products—would be left. After about 10 years, the fission-product activity is dominated by just two isotopes, cesium-137 and strontium-90. They are soluble in water, so they must be securely contained. However, since both have half-lives of about 30 years, their activity is down by a factor of 1,000 after 300 years, and by then they are no longer a significant hazard.

The transuranics can indeed be removed and consumed. A combination of pyrometallurgical recycling and fast reactors can do it, operating at the back end of the current thermal-reactor cycle. The long-term proliferation benefit is obvious—plutonium is removed from circulation and consumed.

Making an early decision in favor of reprocessing would eliminate the waste-security concern, since the radioactivity of the fast-reactor waste falls below that of the original ore in less than 500 years.

But not just any type of reprocessing. Only in a fast neutron spectrum can all the plutonium and other long-lived transuranic isotopes be consumed. A point perhaps understressed in the APS statement is that “breeders” (translation: fast-neutron reactors) must be part of the recycling system.

Reprocessing fuel from current (thermal) reactors to cycle the plutonium back into those same reactors cannot come even close to doing the job. Even with such recycling, less than 1 percent of the energy latent in the mined uranium can be used, versus 99+ percent with fast reactors (the factor 50 in the APS statement is a gross underestimate).

An important proliferation consideration not mentioned in the APS report is that the pyrometallurgical reprocessing that is made possible by metal-fueled fast reactors never produces plutonium with the chemical purity needed for weapons. This is sharply different from the PUREX process now used (but not in the United States) for recycling plutonium in oxide form back into thermal reactors. When the U.S. ban on reprocessing was instituted, “reprocessing” was synonymous with PUREX. That is no longer true.

Arguably, enriched uranium is a more pressing proliferation concern than plutonium. Therefore it is worth noting that, since fast reactors breed their own fissile material, they can eliminate the civilian need for uranium enrichment facilities.

Bearing directly on the second and third of the APS recommendations (pertaining to international controls), but ignored in the report, is the “hub-spoke” concept. The idea is that “nuclear batteries”—self-contained nuclear reactors, perhaps in the 100–300 MWe range—would be manufactured at a central location and rented to nations needing more energy. The units would be sealed and fail-safe, to be run by operators with little by way of nuclear expertise. At the end of their 20-odd year life, the exhausted reactors would be traded for rejuvenated ones. Such concepts have been discussed by Seinicki et al [1], Wade [2], and Feiveson [3].

In summary, there is much of value in the APS report, especially background information about proliferation and current activities. In a significant contribution to a rational global energy policy, it clearly recognizes that the international spread of nuclear power is inexorable. It fails, however, to describe how nuclear power can be managed to address proliferation concerns, and therefore offers little help in formulating for diplomatic initiatives.

[1] James Sienicki et al, “STAR Performer.” *Nuclear Engineering International*, pages 25–28 (July 2005). “STAR is an advanced portable reactor that could provide electricity, hydrogen, and potable water.”

[2] D.C. Wade, “The STAR Concept: a Hierarchical Hub-Spoke Nuclear Architecture Based on Long-Refueling-Interval Battery Reactors and

Regional Fuel Cycle Centers.” Annex 11 of Innovative Small and Medium Sized Reactors: Design Features, Safety Approaches and R&d Trends. Final Report of a Technical Meeting Held in Vienna, 7–11 June 2004. IAEA-TECDOC-1451, pages 171–191 (May 2005)

[3] H. A. Feiveson, “Comments on the Development Path Needed for Proliferation-Resistant Nuclear Power.” *Published in New Energy Technologies: A Policy Framework for Micro-nuclear Technology, Rice University, August 2001.* http://www.rice.edu/energy/publications/docs/NewEnergyTechMicroNuclear_MainStudy.pdf

Gerald E. Marsh is a physicist, retired from Argonne National Laboratory, who has worked and published widely in the areas of science, nuclear power, and foreign affairs. He was a consultant to the Department of Defense on strategic nuclear technology and policy in the Reagan, Bush, and Clinton administrations, and served with the U.S. START delegation in Geneva. He is a Fellow of the American Physical Society. His most recent book is The Phantom Defense: America’s Pursuit of the Star Wars Illusion (Praeger Press).
geraldmarsh63@yahoo.com

George S. Stanford is a physicist, retired from Argonne National Laboratory. B.Sc. with Honours, Acadia University; M.A., Wesleyan University; Ph.D. in experimental nuclear physics, Yale University. He is a member, American Nuclear Society, and a past member of the American Physical Society. He has served on the National Council of the Federation of American Scientists.

Co-author: Born Secret: The H-Bomb, the Progressive Case, and National Security (Pergamon, 1981), and Nuclear Shadowboxing: Contemporary Threats from Cold-War Weaponry (Fidlar Doubleday, 2004). His technical publications have pertained mainly to experiments in nuclear physics, reactor physics, and fast-reactor safety.
George Stanford <gstanford@aya.yale.edu

4S (Super Safe, Small and Simple LMR)

Akio Minato

The 4S (Super-Safe, Small and Simple) reactor is a small sodium-cooled fast reactor that is being developed to serve as a dispersed energy source for the global market, such as for remote areas with high electricity costs or developing countries with small electricity consumption. To meet the needs of this market, the 4S reactor has been designed on the principle of simple operation, simplified maintenance including refueling, higher safety and improved economic features. The 4S reactor is a metallic fueled sodium cooled fast reactor. The electrical output is 10-50 MW. CRIEPI (Central Research Institute of Electric Power Industry) started work on the 4S project with Toshiba late in the 80’s and the 4S has been presented to IAEA (International Atomic Energy Agency) as an energy source for producing potable water from a seawater, which is nuclear desalination.

Design Requirements for 4S

Top level design requirements for 4S reactor include the following ten items:

1. No refueling for 10 or more years,
2. Simple core burn-up control without control rods and driving mechanism,
3. Removal of control and adjustment components from the reactor system,

4. Quality assurance and short construction period based on shop fabrication,
5. Load following without operation of reactor control system,
6. Minimum maintenance and inspection of reactor components,
7. Negative reactivity temperature coefficients including coolant void reactivity,
8. No core damage in any conceivable initiating events without reactor scram,
9. Safety system not dependent on the emergency power and active decay heat removal system,
10. Complete containment of reactivity under any operational conditions and decommissioning.

Based on above design requirements, 4S reactor has incorporated a high level of passive safety characteristics. In the design of 4S reactor, a neutron reflector is selected for the control of the core reactivity in place of neutron absorber rods used in the existing reactors. The reflectors are driven from outside of the reactor vessel and move very slowly. Electromagnetic pumps are applied to the primary pumps. These design features reduce moving parts and decrease component failures and many maintenance requirements.

Safety and Reliability

The safety and reliability features in 4S design are as follows;

- (1) Negative reactivity temperature coefficients including coolant void reactivity,
- (2) No core damage in any conceivable initiating events without reactor scram,
- (3) Safety systems are not dependent on the emergency power and active decay heat removal,
- (4) Complete containment of radioactivity under any operational and accident condition and decommissioning.

All temperature reactivity coefficients are designed to be negative, which strongly helps to realize the passive safety features. It also enables simplification of the power control system so that only feed water control can be used to regulate reactor power. The other safety features of 4S include:

- (5) Simple core burn-up control without control rod and its rod driving mechanism,
- (6) Quality assurance and short construction period based on factor assembly,
- (7) Minimum maintenance and inspection of reactor components.

Reactor Size and Market

4S reactor is a small sodium-cooled fast reactor in which intensive efforts are concentrated with an aim at meeting the global power source market. To correspond to the global market, 4S reactor has been designed on the principle of simple operation, simplified maintenance including refueling, higher safety and improved economic features.

To supply stable and reliable energy source to various remote populated areas is one of the most important tasks of the nuclear technology for sustained growth of mankind in the future. These areas may be remote islands or deep interior regions where sophisticated technological infrastructure is not expected and whose power demands are generally modest. The benefits of nuclear energy will best be brought to these communities by a small and simple power generation.

4S will be applied to supply the electricity and also will be applied to the nuclear desalination as one of the energy sources. 1 MWe can produce about 4,000 m³/day by the reverse osmosis desalination system. 10 MWe will produce 40,000 m³/day. If the

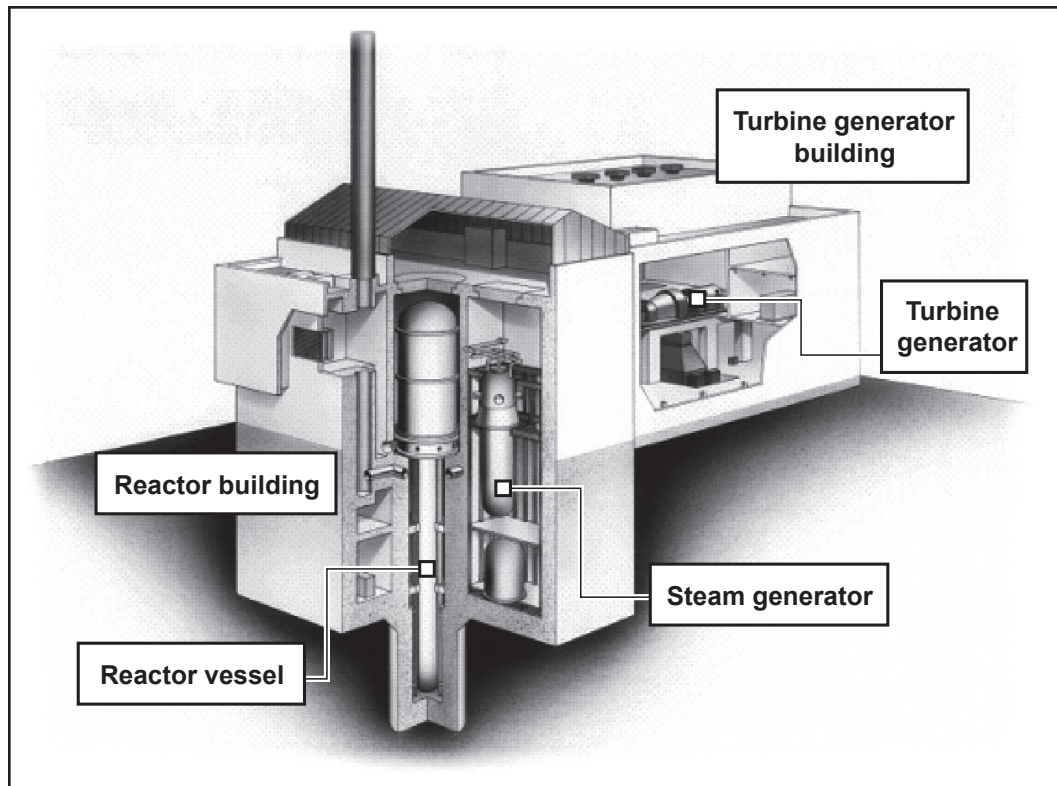

Fig. 1 Reactor building of 4S

required per capita fresh water is 0.5 m³/day, which is an average in Tokyo, Japan, the population of 80,000 can be supplied fresh water. If the required fresh water is 1/5 compared with Tokyo, fresh water can be provided to a population of about 400,000. There are many developing countries, such as in the Middle East, along the Mediterranean Sea and that would benefit from such a system. Then, 10 MWe of small reactor has a big potential to provide fresh water for the world.

Fuel cycle options

A metallic fuel is used in 4S core, taking account of its inherent safety and pyro-reprocessing to recycle and minimize the volume of high level waste. The reactor is designed to operate in a closed fuel cycle with reprocessing of fuel. The reactor core operates for 10 or more years without refueling and reshuffling of fuel. The spent fuel will be sent to the regional or national center for the reprocessing following refueling.

A fast reactor technology using a metallic fuel cycle (pyro-process of spent fuel) is the most developed recycling approach. The technology is valuable because it has the potential to simplify reprocessing, fuel fabrication process and nuclear waste disposal, and it also reduces the fuel cycle cost.

Waste Management and Environmental Impacts

The total high level waste from 4S will be reduced compared with the conventional reactors and the minor actinides will be consumed in the reactor. If 4S is used for the production of fresh water for the plantation in desert regions or similar places, carbon dioxide will be removed by the new plant growth. The present 4S design is not a breeder reactor. However, spent fuel from 4S will

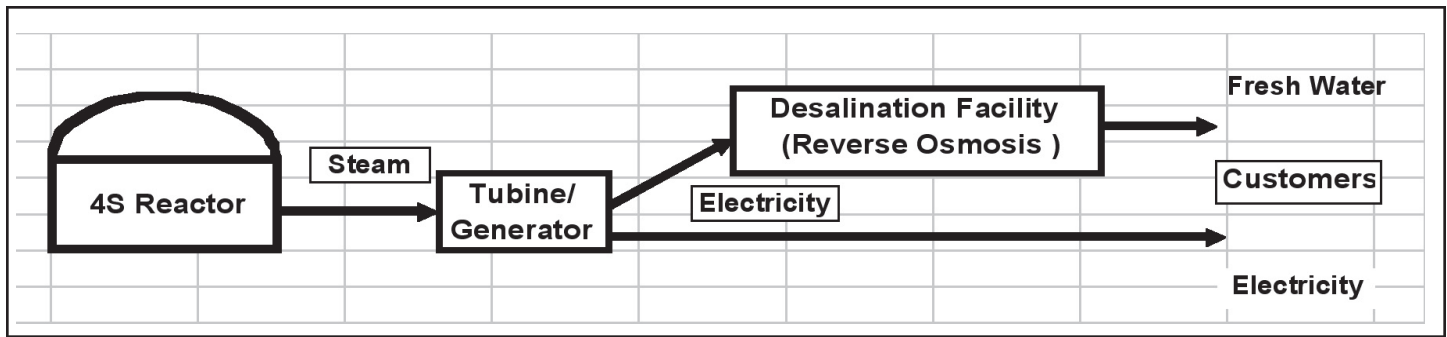

Fig. 2 Application of 4S to provide electricity and fresh water

be reprocessed and Pu will be extracted along with minor actinides for use in recycled fuel.

Proliferation resistance

4S has a high level of proliferation resistance due to the long life core without frequent refueling. Because of the long period (more than 10 years) between refueling it may be possible eliminate any need for on-site refueling equipment and a lengthy period of on-site storage of the fuel. Refueling of the 18 fuel assemblies can be accomplished in a very short time and with special shipping casks removed from the site to the recycling facilities. Also, the fact that access to the nuclear system is unnecessary during normal operations means that access to the fuel and source of neutrons is restricted and easily monitored.

Cost and economy

The simplified design features in 4S are necessary to support installation of plants at remote locations in the developing or in developed countries. As the simplicity of the reactor is further advanced by having these features, it was found that the materials weight per output of 4S reactor structure is lower than that of a large reactor. Costs for the design, production facility, plant construction and operation for nuclear reactors are leveled by the number of production units. The major part of cost for mass products are the costs of the materials and inspection, and the cost is ultimately determined by the material cost if the automation of inspection work is advanced. Therefore, it is characteristic that the reduced volume of bulk material weight directly governs the economic feasibility of the reactor. As a result, the construction cost will be reduced, under the condition that 4S are manufactured at a rate of 10 units a year continuously for 10 years by a plant exclusively designed for the purpose, compared with the construction costs in a case where only one reactor is manufactured. An additional cost merit of small reactors is that the total development cost for commercialization is dramatically smaller than that of large reactor. The cost study of 4S with 50 MWe in JPFS (Joint Preliminary Feasibility Study) shows the busbar cost is around 40 cents/kWh, which was estimated by the same way for S-PRISM and ENHS.

Summary

The target power for a standard 4S design is 50 MWe with 30 years long life core. However, the fundamental design can be implemented at power levels from 10 to 50MWe to meet the power

requirements in developing countries or remote areas. Recently, the village of Galena, Alaska, US, has expressed an interest in a 10MWe sized 4S in order to avoid the high electricity cost and to lead development for potential other applications in the State. Also other small communities in Alaska are interested in small nuclear power plant with very small capacity, such as 0.5-2 MWe.

Because of this interest, CRIEPI and Toshiba are going to request a pre-application review of the 4S with the US-NRC with the objective of future commercialization.

Acknowledgement

The author wishes to thank Mr. N. Brown, LLNL, USA, for his valuable comments on this report.

References

- 1) S. Hattori, N. Handa, "Use of Super-Safe, Small and Simple LMRs to Create Green Belts in Desertification Area", *Trans. ANS., Vol.60 (1989)*
- 2) A. Minato, N. Handa, "Small LMR Electric Power for Small Grid", *3rd International Conference on Nuclear Option in Countries with Small and Medium Grids, Croatia Nuclear Society, June, 2000*
- 3) "Small Modular Nuclear Reactors", *US-DOE-NE Report to Congress, May 2001*
- 4) N. Ueda, I. Kinoshita, Y. Nishi, A. Minato, T. Yokoyama, Y. Nishiguchi, "Current Design Status of Sodium Cooled Super-Safe, Small and Simple Reactor", *ICONE10-353, 10th International Conference on Nuclear Engineering, April, 2002, Arlington, USA,*
- 5) D. Wade, N. Brown, J. Choi, E. Greenspan, W. Halsey, A. Minato, C. Smith, D. Vogt, "Liquid Metal Cooled Reactors and Fuel Cycles for International Security", *11th International Conference on Nuclear Engineering, April 20-23, 2003, Tokyo Japan,*
- 6) N. Brown, D. Wade, A. Minato et al., "Joint Preliminary Feasibility Study", *UCRL-TR-201726 (Controlled Distribution), December, 2003*
- 7) C. Smith, D. Crawford, M. Cappiello, A. Minato, J. Herczeg, "The Small Modular Liquid Metal Cooled Reactor: A New Approach to Proliferation Risk Management", *14th Pacific Basin Nuclear Conference, "New Technologies for a New Era", March 21-25, 2004, Honolulu, Hawaii, US*
- 8) O. Okcek, P. Babka, G. Pavlenko, K. Kemmerer, "1994 ALMR Capital Busbar Cost Estimats", *GEFR-00940, March 1995.*

Akio Minato
Senior Research Scientist
Sector, Advanced Reactor System
Nuclear Research Laboratory
Central Research Institute of Electric Power Industry (CRIEPI)
2-11-1, Iwado-kita, Komae-shi, Tokyo 201-8511
Phone: +81-3-3480-2111
Fax: +81-3-3488-2844
Mobile: +81-70-5860-5038

Strawbale Construction — Low Tech vs. High Tech or Just better physical properties?

Ken Haggard

1. Introduction

Invented by pioneers in the great plains of North America in the 1890s, strawbale construction techniques have been resurrected during the last ten years. Strawbale construction generally consists of stacking standard size agricultural bales to form the exterior walls of buildings. These walls are then sealed by stuccoing both the inside and outside of the walls. Walls of this sort can be used as infill, within a separate structural frame or with some engineering they can become the building's structure as well as the building envelope. In California, we have permitted and built stuccoed strawbale walls that handle both gravity and seismic loads without additional structural elements and several of these have done very well in recent earthquakes. In these cases the stucco skin acts as a thin shell with its adhesion to the bales preventing local buckling of the shell.

Recent applications have used bales with standard platform framing to produce multistory bale buildings. There is also a lot of work occurring using other methods of sealing the bales such as lime and earthen plasters. Since the rediscovery of this approach to building about 10 years ago, thousands of strawbale buildings have been built worldwide. For example, there are at least sixty in our county alone on the central California coast.

Strawbale construction has been described as a romantic low tech fashion by many industrial oriented builders and architects but the advantages of this type of construction is that it offers a better physical response to many of today's building needs. This article will discuss some of these advantages starting at the larger scale of concerns and going to the smaller ones.

2. Planetary Scale

We raise most grain on an industrialized basis, which results in a great concentration of straw once the grain is removed. This straw, particularly rice straw, is very tough and hard to compost and is therefore considered a troublesome waste product. Growers have been getting rid of rice straw by burning it but this produces prodigious amounts of air pollution and adds to the CO₂ load in the atmosphere. Increasing regulation to prevent this method of disposal has developed but a more positive solution is to creatively use this straw. Constructing buildings from straw, particularly rice straw, is one of these creative approaches for the properties that make this material troublesome also make it a superior building material. Strawbale construction (see Figure 1) allows a better building while simultaneously having less impact on the planet. Pollution isn't produced from burning and carbon is sequestered in the new buildings rather than contributing to climate change. If we do this on a large enough scale, we can also reduce the pressure on our forests, which in their turn also sequesters carbon, cleans air, creates healthy watersheds and provides beautiful environments and wildlife habitat. Performance prediction models like Energy 10 begin to allow us to calculate many of these benefits so that they can become part of life cycle design and analysis of a building. This type of information can be used in green building certification programs like LEED (Leadership in Energy and Environmental



Figure 1: Constructing an infill strawbale building.

Design) created by the U.S. Green Building Council to document the benefits and true costs of a Green Building.

3. User Scale

A strawbale building provides a very different feeling from standard buildings. This is because thick walls are so rare in industrial era architecture which generally uses relatively thin materials such as steel, plywood or concrete panels. Many people like the substantive feeling of the thick walls, deep inset doors and windows, window seats and handy niches that can result. Since the strawbales are easy to carve and restring they offer unique aesthetic opportunities. The more complex geometry of curves can become part of the building composition at little extra cost. Curving the walls and carving the ends are easily accomplished with such simple tools as chainsaws and bale-saws. Interplaying complex shapes with a feeling of solidity are natural aesthetic directions with strawbale construction technology.

Another consideration at the user scale is concern with indoor air pollution caused by building with unhealthy materials. Various insulations, adhesives, and many paints have traditionally been the culprits in this situation. Strawbale construction eliminates much of the more industrial based insulation and if one uses a fine gypsum finish for the finish coat of the interior stucco wall, we can eliminate the need for paint on large areas of the building. Simplifying the building components to just bales and stucco reduces the need for glue and caulking in many areas as well.

A simple experimental test of the difference in this regard is to visit a standard residence during construction after the insula-

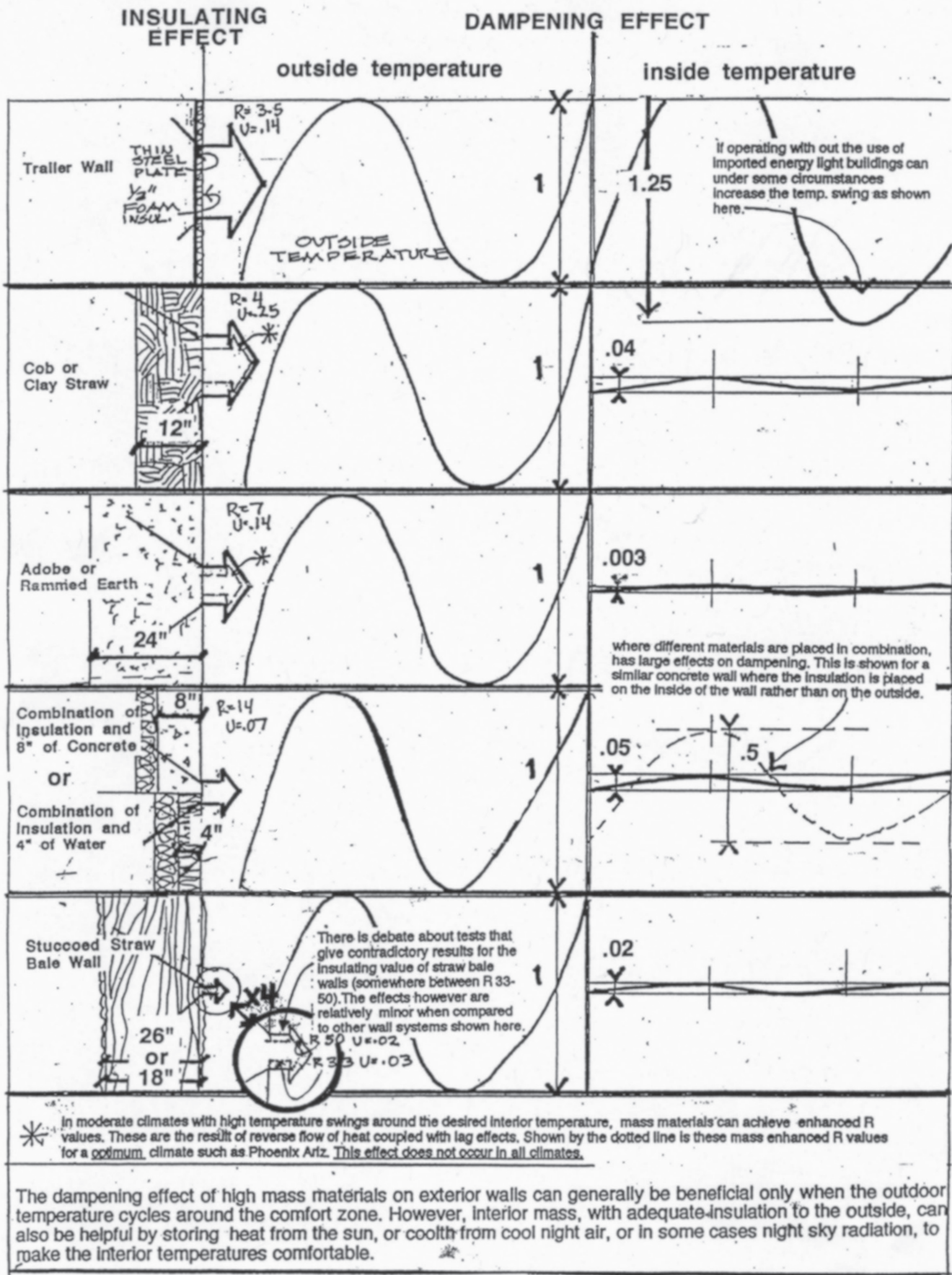

Figure 3: Insulating Effect and Relative Temperature Dampening Effect



Figure 2: *Passive solar strawbale building design in Santa Margarita, California.*

tion, wiring, windows, etc. have been installed. One usually will experience a tightening of the throat and other subtle discomfort. This is because there is so much toxic material being used in the interior, soon to be living space. A visit to a strawbale building at this phase of construction will be a different experience.

The biggest area of potential improvement in strawbale construction in regard to health is to reduce the use of Portland cement to a minimum. This is because large amounts of Carbon Dioxide is added to the atmosphere by the manufacture of cement. This is why a lot of work is being done with lime and earthen plasters for strawbale construction.

Philosophical concerns and ease of construction with friends and neighbors meant that the first of this new generation of bale buildings were simple small residences. Over the last several years however strawbale construction has spread to larger, fancier residences. Recently strawbale construction is starting to be used for part of green public buildings such as places of worship, and education facilities.

4. Building Scale

Compared to standard residential construction, strawbale buildings have better insulation qualities resulting in a quieter and more thermally efficient indoor environment. A standard strawbale wall provides about three times the insulation value of a standard stud wall with fiberglass insulation (R-30 vs. R-11). There have been some interesting recent approaches to using bales for roof components to increase roof insulation as well.

Strawbale walls are more fire resistant than standard wood frame construction. The stucco coating on the interior and exterior of the bales prevents oxygen from reaching the compact cellulose of the bales in quantities that allow rapid combustion. Burning a bale is like trying to burn a dense stack of phone books. Bale walls have a two hour fire rating in most building applications while by contrast we have to use two layers of special 5/8" gypsum board to get a one hour rating with standard wood framing.

Strawbale components have additional advantages if we look at the building as an integrated thermal whole. The increased insulation of the wall and the distributed thermal mass of the stucco interior skin work together to help create a passive solar building. A passive solar building is one that is properly oriented and tuned so that it largely heats and cools itself using intelligent proportions

of sun, shade, cool night air, thermal mass and insulation. If done correctly, a passive solar building can provide greater comfort at less cost and more security since the amount of energy needed to be imported to the site to operate the building is greatly reduced (see Figure 2).

5. Component Scale

Building walls have traditionally been thought of as a simple element that serves only one discrete function. However, strawbale construction, once stuccoed, is a composite that can serve several functions, besides just being a building envelope. Functions important to a passive solar building involve providing insulation and thermal mass. The differences between these are often confused in the building industry. Insulation is what moderates heat flow in and out of the building. It is analogous to resistance in an electrical circuit. Thermal mass is different. Thermal mass holds heat or cools and thus moderates the temperature swing in a building. It is analogous to a capacitor in an electrical circuit. It just happens that a stuccoed strawbale wall has for many temperate climates an optimal relationship between this insulation to reduce heat flow, and thermal mass to moderate interior temperature swings. Since thermal mass is expensive it needs to be used most efficiently. For a passive buildings that involves both solar heating and night ventilation cooling in many temperate climates two inches of distributed masonry is close to optimal. This is very close to what occurs in the three coat stucco finish on the interior of a strawbale wall. The relationships, between insulation and mass is shown comparatively for various building systems in Figure 3. It shows why strawbale building technology is such a good fit for passive solar buildings.

An additional advantage of strawbale construction deals with maintenance and longevity. As mentioned before there are 110 year old strawbale buildings still in use. Stucco traditionally applied to plywood panels in light frame construction experiences a lot of cracking. This is because the coefficient of expansion of the two materials is different. Plastered strawbale construction has less cracking because the expansion and contraction of the stucco is not in conflict with that of the straw upon, which it is applied. The straw is flexible enough to move with the stucco while still providing excellent "tooth" for the stucco layer to attach to.

6. In Summary

Strawbale construction has many advantages in contemporary construction when its unique physical properties are taken advantage of. In spite of being considered by some as being a romantic low-tech fad, it has very specific advantages regarding waste, energy and construction processes. This type of building technology is a part of our transformation from highly developed but depleting industrial processes to information-based sustainable processes. This is a transformation that is occurring in many fields, besides architecture and it is critical to our future.

Ken Haggard
San Luis Sustainability Group Architects
 16550 Oracle Oak Way, Santa Margarita, CA 93453
 E-mail: SLOSG@slonet.org
 Phone: (805) 438-4452, Fax: (805) 438-4680
 www.slosustainability.com

LETTERS

Intelligent Design: Not Necessarily Religion

This is a quick response to Alan D. Franklin's letter in the October 2005 newsletter. One of the things that sets Intelligent Design apart from the other flavors of Creationism is that it doesn't *require* the supernatural. The Designer can simply be an advanced alien intelligence using scientific methods to tinker with life on our planet (as is believed by the Raelians), with life on the Designer's planet having evolved through a "clearer" naturalistic process. In other words, there would be no unjumpable gaps in the Designer's evolution, but due to the Designer's intervention on Earth, we do have unjumpable gaps.

Granted, most ID proponents are simply hiding some variety of the Judeo-Christian God behind their curtain, and invoking supernatural causes without calling them supernatural. But ID does not require the supernatural, however often it acts as a beard for the supernatural. (Disclaimer: I don't believe in any flavor of ID, I just felt that the point needed to be addressed lest anyone get into an argument with a true believer and end up blindsided.)

*Dave Van Domelen
Director of Undergraduate Labs
Physics Department, Kansas State University
dvdandom@phys.ksu.edu*

Worrying About Science vs Religion a Waste of Time?

Science consists of a set of consistent models that attempt, with a varying degree of success to explain the natural world. These models make no pretense to being true, and are only useful so long as they work. When they don't they are discarded unless the breakdown occurs in a sufficiently isolated region for them to be modified in that region.

Religious approaches on the other hand start from the premise that they are true, and that distinguishes faith from science. But science is based on experimental observations that often provide contradictory results, and faith is often involved in which set of results are accepted. In some cases acceptance of some results becomes controversial, and are described as "non-science" by the sceptics.

The distinction between science and non-science has intrigued philosophers of science, and some years ago Larry Laudan published a short paper entitled "The Demise of the Demarcation Problem" in which he showed that the distinction could not be made. He ended the paper with the remark that worrying about the distinction was a waste of time which would be better spent on subjects which were "heuristically profitable". It seems to me that the same comment applies here.

*Derek Walton
Dept. of Physics and Astronomy
McMaster Univ., Hamilton, Canada
waltond@mcmaster.ca*

Physicists should be Defending Evolution

Evolution is under continuous attack, its defenders are losing, badly. The blasphemous (un)intelligent design views are winning. Why are we failing? In part we do not understand what the fight is about so offer irrelevant, thus ineffective, arguments. We are treating the wrong disease (and that badly). This is about neither science nor religion, but self-image and group identity. Unless we deal with these our position is hopeless. "Those who believe in God are good people, those who do not are bad". "Those who believe in evolution do not believe in God thus are bad people. Being opposed to evolution shows that I believe in God and am good." Actually evil people who believe in the blasphemous creation and ID theories are angry at God because It did not create the universe the way they want. They think they are better than God, showing contempt for God, regarding words of humans as superior to those of God as shown in Its work, the natural world. They push these blasphemous theories in order to flaunt their anger at ,contempt for, God. Evolution leads to morality, thus they oppose it. This must be stressed again and again.

Here is a brief outline for action, discussed in depth in my next book "Our Almost Impossible Universe: Why the laws of nature make the existence of humans extraordinarily unlikely".

We must not ask students to believe in evolution. Belief is a religious word. They should know: what evolution is, how it works, why it is valuable, how that is determined, and why no other theory is. They can believe anything they want. They can believe the earth is flat, but know the evidence that it is (roughly) spherical. They can believe in ghosts. Schools should not have courses in ghosts.

Force them into ridiculous positions where they have to admit they do not know what they are saying. How did the creator create? Did it draw pictures, blueprints, write a computer program, ...? Which part of its brain developed the design? Its prefrontal cortex? Does the designer's brain have neurons? With myelin sheaths? And on and on. How did it interact with matter to make that conform to its designs? Does it have hands? Did it blow on matter? Else how?

If they cannot answer they have to admit that their words are meaningless—hot air. To give sense to what they claim they must regard the designer as a human being, perhaps a superior one but a human nevertheless, clearly blasphemous.

Challenge them. Present many examples of how evolution is valuable, helps us understand nature, guides us to learn more, to cure diseases, Then ask how their beliefs do so. What explanatory powers, values, do they have? Prove it. Examples are given in my book. A web site with more would be invaluable.

It is our responsibility to teach, not only biology, but the meaning of science, how it works, why. The fight about evolution emphasizes our incompetence, cowardliness, failure, irresponsibility.

*Ronald Mirman
SSSBB@CUNYVM.CUNY.EDU*

REVIEWS

Twilight in the Desert: The Coming Saudi Oil Shock and the World Economy

By Matthew Simmons, John Wiley & Sons, Hoboken, NJ. (2005), 422 pp., ISBN-13: 978-0-471-73876-3

This book is a comprehensive examination of the history of Saudi Arabia's petroleum extraction and how much remaining Saudi oil can be extracted in the future. The author is Chairman and CEO of Simmons & Company International, a Houston-based investment bank that specializes in the energy industry, and a member of the National Petroleum Council and the Council on Foreign Relations, with an MBA from Harvard. Of the book's four parts, the first two give background and history while the last two report Simmons' detailed analysis of technical papers from Saudi Arabia.

Simmons gives the history of early Saudi oil production in considerable detail. Saudi Arabia did not become a major player in world petroleum production and politics until after U.S. petroleum production peaked in 1970 and the U.S. consequently became increasingly dependent on imported oil. The Saudis had been producing 2.5 million barrels a day in 1965, and this leaped to 8 million barrels a day by 1974. Yet these rapid increases were causing damage to the oil fields. Many experts believe that total ultimate recovery of oil from a field can be reduced by extended periods of high production. Ironically, in trying to meet its responsibilities as swing producer, Saudi Arabia probably violated the principles of good stewardship of its great oil fields. To maintain reservoir pressure, water was injected into the oil fields. By 1976, the Ghawar oil field was injecting 9.2 million barrels of water per day to produce 5.9 million barrels of oil per day.

As Simmons explains, the world knows so little about Saudi oil fields because in 1982 the Saudis ended their previous practice of publishing detailed production data. Nor have any data been released about remaining proven OPEC reserves. "Official OPEC production and reserve data have been sparse and utterly unverifiable. As a result, few oil observers trust OPEC's published petroleum data. OPEC members have many reasons not to be candid about reserves, production rates, and maximum capacities, and few incentives for being truthful."

Simmons shows in detail how this lack of information supported the belief that oil supplies in Saudi Arabia were nearly infinite, and this contributed to the collapse of oil prices in the spring of 1999 which sent the wrong message to oil "experts." Many writers with little or no background in science interpreted the price collapse as a sign that OPEC reserves were so large that OPEC could effectively pump oil at high rates forever. For just one of many such examples, M.I.T. economics professor M.A. Adelman wrote (*Regulation*, Spring 2004, Pg.16) that "There is not, and never has been, an oil crisis or gap. Oil reserves are not dwindling. The price of oil should be relatively stable." The collapse of petroleum prices caused the shutdown of many petroleum exploration efforts as well as shutting down development of alternative energies because they were not economically viable

when compared to the low cost of petroleum.

Faced with the absence of good information from which he and other outside experts could deduce the condition of the Saudi oil fields, Simmons found an indirect source of information: some 200 technical papers on various aspects of Saudi production problems that had been published in respected refereed petroleum engineering journals. From these, and from his extensive general knowledge of the oil business, he put together a detailed picture of the current (2004) status of each of the Saudi oil fields and the results of extensive Saudi exploration for new oil fields. He concludes that Saudi oil production is very close to its "Hubbert Peak" after which production will start to decline. This in contrast to the Saudi claimed intention to pump "15 million barrels per day for 50 years even without the new oil discoveries they insist could add another 200 billion barrels of oil."

Simmons' studies do not support this optimism. He writes: "It is natural for energy optimists to take all the senior Saudi Arabian oil officials' vocal assurance at face value. As Saudi oil fields age and the world's need for oil steadily rises, the probability increases...that we are approaching an oil-curtailling twilight in the desert kingdom that has provided the greatest single contribution to the world's oil supply at the least cost. When this desert twilight arrives, the world faces an energy future, and in turn an economic future, far different from the one that all current forecasts and human expectations assume."

In an article in *World Energy* (Vol.8, No.2, 2005) Simmons recapitulates his studies and his conclusions, as well as giving an account of how he came to be involved in these studies. Here are some of his observations:

My hope is that [the book] will serve as a wakeup call to the urgency and importance of understanding the limits, not just to Saudi Arabia's oil, but to the entire world's oil supply, because we are clearly approaching the peaking of global oil supply at the same time as the world faces a relentless increase in oil demand.

For the past 15 years, I have become increasingly concerned that all was not well in the oil and gas world, and I have stated my convictions many times. I grew more and more convinced that the purveyors of conventional energy wisdom were peddling an energy blueprint for the 21st century that was fundamentally wrong.

Virtually every oil expert in the world has believed that Middle East oil is so plentiful that it will provide an essentially inexhaustible supply of inexpensive petroleum for the next 30, 50, or even 100 years. No one I ever met, however, had any facts to support this conclusion. The concept was based either on pure optimism or on readily available numbers that had not been audited.

Whenever our society faces a major crisis, a loud cry arises from Congress to investigate in order to determine who was at fault. We can expect this to be repeated when world oil production peaks and gasoline prices continue their rapid rise. Already it is

clear that much of the blame and responsibility will have to be assigned to the Congress. Simmons describes a 1979 *New York Times* article that reported on closed-door hearings in the U.S. Senate in 1974 in which the “senators were told that the Saudi oilfields were being worked so hard that a cutback in output would soon be mandatory.” On my desk, my “bible” is a 1974 report, *U.S. Energy Resources, A Review as of 1972* authored by M. King Hubbert and presented as a background paper prepared at the request of Henry M. Jackson, Chairman of the Committee on Interior and Insular Affairs of the U.S. Senate. In this 265 page report (Serial No. 93-40 (92-75), Part 1), Hubbert sets forth his methods of analysis and applies them to U.S. and to world oil, as well as to other fossil fuels. He predicts production peaks in the U.S. and world oil production. The report’s forecasts have proven to be pretty much correct. When the global oil crisis becomes apparent to all, it will be interesting to see if the Congress will acknowledge its failure to act responsibly in the 1970s and in the many decades since. Quite recently Congressman Roscoe Bartlett (R-MD) (we are not related), who is a scientist, has been trying valiantly to educate his colleagues about the Hubbert Curve and its predictable imminent global effects. I have not seen signs that his colleagues are paying attention.

While I can’t evaluate Simmons’ claims, I find the presentation thoughtful, coherent, well-presented, and scientifically convincing. He stresses the topics on which information is unavailable or uncertain, and he carefully expresses his conclusions in terms that reasonably reflect the uncertainty in the input information. The Saudis have disputed Simmons’ claims, so the ball is now in the Saudis’ court. If they wish their claims about their projected future high levels of their oil production to be taken seriously, they must unveil their data for the world to evaluate. We scientists need to be aware of the great anti-scientific efforts of those who would have us believe that resources such as petroleum are effectively infinite.

This is an impressive book. On the book jacket is an endorsement by Nobel Laureate (Chemistry 1996) Richard Smalley who writes, “This book is likely to be the most important ever written about oil.”

Albert A. Bartlett,
University of Colorado
Albert.Bartlett@Colorado.EDU

The End of Oil: On the Edge of a Perilous New World

by Paul Roberts, Houghton Mifflin, 2004, 389 pp., \$26, ISBN 0-618-23977-4.

The Hydrogen Economy: The Creation of the Worldwide Energy Web and the Redistribution of Power on Earth

by Jeremy Rifkin, Putnam, 2002, 295 pp., \$24.95, ISBN 1-58542-193-6..

This review is reprinted from the *Teachers Clearinghouse Newsletter on Science and Society*, Spring 2005, with permission.

When I set out to read these books, I expected from their titles that they would cover two different aspects of energy sources in our history, that the first would paint a gloomy picture of life on Earth as its oil resources are depleted and that the second would focus on what life would be like in a future fueled by hydrogen. Although these expectations were borne out to some extent, I was struck more by how much these two books had in common.

For example, they both characterize the ages of societal development by their energy sources: hunter-gatherer stage by human energy, agricultural stage by solar and animal energy, industrial stage by fossil fuels. They both warn of the impending peak of global oil output and of the dangers of “holding on” to our present fossil fuel reliance rather than planning for alternatives. They both see the world oil picture in light of expenses to maintain the royal family of Saudi Arabia, Islamic fundamentalism, and China’s growing appetite for oil. They both see global warming as a further danger posed by continued reliance on fossil fuels, with greater danger posed by the possibility that insufficient oil will lead both China and the United States to burn coal or oil substitutes (like oil from shale and tar sands), all of which will emit even more carbon dioxide. They also note that the first advocacy of hydrogen as a fuel came from geneticist J. B. S. Haldane in a 1923 Cambridge University lecture.

That said, let us now turn to how the books differ. One of the reasons they differ is the backgrounds of their authors. Roberts is a journalist, who in turn is dependent upon those he interviews and reads for his expertise. Because of the huge investment tied up in our fossil fuel infrastructure, a phenomenon Roberts calls “asset inertia,” he confesses in his conclusion that the onset of writing his book found him pessimistic about continuing “business as usual” with fossil fuels. This comes through in several statements:

- “The real question, for anyone truly concerned about our future, is not whether change is going to come, but whether the shift will be peaceful and orderly or chaotic and violent because we waited too long to begin planning for it.” (p. 14)
- “The real question is not whether oil is going to run out (it will) but whether we have the capacity, the political will, to see that outcome soon enough to prepare ourselves for it.” (p.65)
- “An even more important question: whether we can produce enough energy by any means to provide a decent standard of living for the entire planet and at the same time satisfy our emerging criteria for climate and energy security. . .” (pp. 210-212)

Yet, Roberts admits that writing the book has left him with a “more complex perspective.” Because natural gas can be converted to liquid fuel and shows promise for generating electricity with lower carbon dioxide emissions than coal, he sees natural gas as a “bridge fuel” to what he calls the “next energy economy,” but he concedes that it is not clear where the “bridge” will lead. However, because the global peak in natural gas output is expected to follow the global peak in oil output by about 20 years, this “bridge” cannot last long.

The future Roberts would like to see, as expressed in his last chapter, is one in which a carbon-emissions tax is imposed

in order to discourage further contribution to global warming. If utilities can be taxed for the sulfur dioxide, he asks, why can't they be taxed for the carbon dioxide they emit? (An initial amount of \$10/ton is suggested, with a ramping up to ten times that in 15-20 years.) Another part of Roberts' vision is raising the Corporate Average Fuel Efficiency (CAFE) standards for automobiles, which remain unchanged since President Reagan froze them in 1987. He would facilitate this by a "feebate" system—extra fees for gas guzzlers (up front, so the prospective purchaser would think about the total cost before buying), and rebates for vehicles getting more than 40 miles to the gallon. He would also subsidize Detroit (which he acknowledges is saddled with the most asset inertia) to compensate for the advantages foreign manufacturers already enjoy at the high end of the fuel efficiency scale (a provision he sees as justified in the name of national security). Raising the CAFE standards by 4 miles/gallon, he points out, would save twice the oil that could be pumped from the Arctic National Wildlife Refuge.

But Roberts feels that the United States needs to do more to show its commitment to a more positive energy future. To match Denmark's leadership in wind technology and Japan's leadership in solar energy technology, he would like to see the U.S., as the world's leading holder of coal reserves, develop leadership in clean-coal technology—and give it to China and India if it is necessary to prevent catastrophic global warming.

If Roberts is not sure what the energy future will bring, Rifkin, writing as the president of the Foundation on Economic Trends in Washington, DC, is very clear about what it should bring. Rifkin's answer is hydrogen, which he calls the "forever fuel," largely because of its abundance in the universe. He sometimes mistakenly associates it with the "power of the sun" (where there is hydrogen fusion, not hydrogen combustion). And while on p. 180 he finally acknowledges that hydrogen fuel is "a secondary form of energy that has to be produced," nowhere does he confront the consequences of this requirement in a quantitative way.

When Rifkin characterizes the ages of societal development by their energy sources, he does so with a particular bent to the type of society necessitated by the energy source. He maintains that "the greater the horizontal flow of energy from environment to society, the greater the vertical flow of societal power from the top down needed to secure the process." (p. 41) He adds on p. 89 that this also means greater production of entropy, which he consistently miscues as energy "no longer able to perform useful work." (p. 44) He applies "thermodynamic" arguments to assert that "Collapse sets in . . . when a mature civilization reaches the point at which it is forced to spend more and more of its energy reserves simply maintaining its complex social arrangements while experiencing diminishing returns in the energy enjoyed per capita." (p. 56) "The complex, centralized infrastructure we have created to manage a high-energy fossil-fueled economy [which Roberts refers to as "asset inertia"]—once our greatest asset—is fast becoming our biggest liability," he adds on p. 144. And on p. 173 he writes that "We are living through the senescent stages of a mature energy regime, with all the problems that go with it." Elsewhere (at the beginning of Chapter 7) he states that we risk danger by paying more to maintain access to Middle Eastern oil than the value of the oil itself.

Rifkin argues that we need to get out from under our present system characterized by corporate domination and vertical control. To argue for the next stage, he goes back to his characterization of societal development stages in terms of energy resources and adds a correlated form of communication. For the industrial stage characterized by dependence on fossil fuels he cites the printing press, telegraph, and telephone, all of which, like the entire industrial age, have relied on central points of dissemination (publishing houses and telegraph and telephone companies are centralized just like electric power plants). But the most recent form of communication, Rifkin observes, is the Internet, which is not centralized, and he sees hydrogen playing the same role as our next energy source as a "Hydrogen Energy Web." This Web will be run as an interconnected system of hydrogen-fueled fuel cells by cooperative DGAs (distributed-generation associations), for which he sees Community Development Corporations, Community Development Credit Unions, public not-for-profit utilities, Common Interest Developments, and cooperatives as either models or candidates. Rifkin sees the Hydrogen Energy Web as "democratizing" energy, and no more so than on the international scale, particularly in terms of "empowering" the developing world, in a double sense of the word, by bringing a source of energy which does not require going into hock by having to pay for ever more expensive oil imports. But he does not confront the problem of how he is going to generate the hydrogen fuel for all these interconnected fuel cells.

John L. Roeder
The Calhoun School
JLRoeder@aol.com

Catastrophe: Risk and Response

By Richard A. Posner, Oxford University Press, 2004, 265 pages text, 48 pages notes and references, ISBN 0-19-517813-0

Richard Posner is a judge of the U.S. Court of Appeals for the Seventh Circuit. As such, *Catastrophe: Risk and Response* is a book intended primarily for the legal community and looks principally at the relationship between the law, science, and technology. Although the book is extremely well documented, Posner is not a scientist and most of his references are not from scientific sources. Exceptions are a few references from *Physical Review*, *Science* and *Nature*. Curiously, even though Posner himself is not a scientist, he often criticizes the opinions of other people on the basis of their being non-scientists.

Posner begins by reviewing various risks to society and categorizing them as either "catastrophic" or "not catastrophic." For the purposes of this book, catastrophic risks are those risks that threaten to kill most or all of human life. Given that definition, the principal catastrophes Posner identifies are the following: (1) collision with an asteroid (as presumably led to the extinction of the dinosaurs 65 million years ago); (2) runaway global warming; (3) a strangelet accident (as was feared might result from the creation of exotic particles at the Relativistic Heavy Ion Collider ["RHIC"] at Brookhaven National Laboratory); (4) a bioterrorist attack of global proportions; and (5) nanomachines capable of self-replication leading to the destruction of all life.

Risks Posner identifies but concludes are not catastrophic (in the sense that they wouldn't destroy most or all of human life) include the following: (1) runaway genetically modified plants; (2) overthrow of the human race by superintelligent robots; (3) pandemics (natural epidemics as opposed to epidemics induced by bioterrorists); (4) major volcanic eruptions; (5) exhaustion of natural resources; (6) loss of biodiversity; (7) overpopulation of Earth; (8) "nuclear winter" resulting from a global nuclear war; (9) cyberterrorism (including computer viruses); and (10) loss of privacy resulting from extreme surveillance and concealment activities.

Of course, most of these risks are interdependent. In both lists, Posner emphasizes the "double-edged sword" of technology; technology often is both the cause but also the potential cure. Probably the only risk that lies almost entirely outside human control is the risk of a collision with a large asteroid. Even in that case, however, Posner explores the possibility of a weapons defense system that could conceivably destroy or at least deflect an asteroid on a trajectory of intersection with Earth.

Posner also considers some "disasters" that many readers probably would not label as such. In particular, he discusses what he calls "moral disasters." Posner seems to deplore the change in the social role of women in recent decades, along with increases in divorce rates, extramarital sex, the status of homosexuals, and safe and effective contraception. It remains unclear to me why these topics were included in this book, and I suspect that many readers would disagree with Posner's stance on these subjects.

A second stance Posner takes that many readers (especially of this newsletter) would probably disagree with is in regards to RHIC. Posner asserts that high-energy particle research offers no benefit to society, so he asks why the federal government even funds such research. In regards to the strangelet scenario, he argues that the construction of RHIC could have been postponed without any ill consequence to society until there was a completely unbiased verdict that a strangelet scenario cannot possibly happen.

A third stance Posner takes that many readers also would probably disagree with is his recommendation to restrict certain foreign students from access to security-sensitive graduate programs in the United States. He says, "... citizens of foreign countries that are hostile to the United States, and citizens of

countries (mainly Muslim) in which a significant fraction of the population is deeply hostile to the United States...should not be admitted to advanced study of dangerous technologies, such as nuclear engineering, nanotechnology, molecular biology, computer science, and artificial intelligence." Posner does state, however, that he recognizes that any restrictions more stringent than what have already been imposed since 9/11 are unlikely to be implemented.

The sections of *Catastrophe* that deal with true catastrophes are well-documented and are worth reading by an audience unfamiliar with any or all of these catastrophes and who would like an introduction to these topics. However, a major part of the book deals with Posner's efforts at providing a cost-benefit analysis of each situation. I found this section tedious to read and largely unproductive in its conclusions. The estimates of the worth of human lives are too subjective, and the estimates of the probabilities or frequencies of occurrences of disasters are too speculative to be of much value.

Posner's principal recommendation of how to deal with possible catastrophes is to establish national or international science courts composed of lawyers and other public-policy makers. Members of these courts would conduct thorough analyses of the risks involved and the costs of attempting to avert those risks, and would then recommend to government agencies suitable courses of action to take. Rather than leaving these analyses to the scientific and technical community, Posner argues for the establishment of a scientifically literate legal profession, largely on the grounds of presumed greater impartiality. I'm sure that professional scientists reading this book would be unlikely to agree with Posner's recommendations.

Overall, *Catastrophe* is probably of greater value to the legal profession and to the general public than it is to the scientific community. However, even general readers of *Catastrophe* should feel free to be selective in which portions they read. Probably the greatest benefit to them of reading the book would be derived by following up on the references that are given. The scientific community may be better served by the peer-reviewed scientific literature.

Dr. Brian H. Nordstrom
Embry-Riddle Aeronautical University, Prescott, Arizona
nordstrb@erau.edu

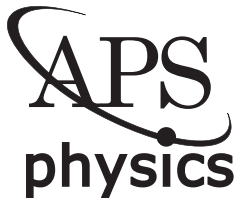

AMERICAN PHYSICAL SOCIETY
Forum on Physics and Society
One Physics Ellipse
College Park, MD 20740-3844