

## Biogas Energy: Unexplored Source of a Renewable Energy in Jordan

Abu-Hamatteh Z.S.H.<sup>1</sup>, Al-Jufout, Saleh<sup>2</sup>, Abbassi, B.<sup>3</sup> and Besieso, M. S.<sup>4</sup>

<sup>1</sup>Faculty of Engineering Technology,  
Al-Balqa' Applied University, Jordan  
P. O. Box: 620088 Amman

Phone number: +962-5-3491111, Ext. 3291, Fax: +962-5-3491105, Mobile: +962-77-7484772  
e-mail: hamatteh@bau.edu.jo, drabuhamatteh@yahoo.com

<sup>2</sup>Electrical Engineering Department, Faculty of Engineering,  
Tafila Technical University, Jordan  
e-mail: drjufout@ttu.edu.jo

<sup>3</sup>Department of Water Resources and Environmental Management,  
Faculty of Agricultural Technology,  
Al-Balqa' Applied University, Jordan  
e-mail: babbassi@bau.edu.jo

<sup>4</sup>Jordan Oil Shale Energy Company PLC, Jordan  
e-mail: munther.besieso@gmail.com

**Abstract.** Jordan is a non-oil producing country. Its basic energy requirements are obtained from imported oil and natural gas from different sources. Domestic natural gas covers only 4% of the Kingdom's energy needs. Energy import costs create a financial burden on the national economy. Jordan spends more than 25% of its GDP on the purchase of energy. Considerable efforts have been made and great progress has been achieved in the application of solar, wind, biogas and hydro energy utilization. This paper explores the potential of biogas as renewable energy in developing countries including Jordan, where access to basic clean energy services is essential for sustainable development. A techno-economic feasibility study for electric power generation from municipal solid waste was carried out in cooperation with the UNDP and the UN Global Environmental Facility has approved the award to finance a pilot biogas plant at Amman municipal waste disposal site. The project rated capacity is 1MW and due to the successful operation, the project was expanded to 3.5MW.

### Key words

Biogas, digester reactor, fermentation, greenhouse gases, internal combustion, landfill, methane.

### 1. Introduction

With recognition that oil and gas supplies are finite, increasing attention has been paid to the wide range of renewable energy sources. All fossil energy consumed today (coal, oil and natural gas) came from the sun's energy, which was stored in biomass for millions of years. These transformed biomasses cannot be regenerated on a human time scale.

However, biomass as such is considered a renewable resource due to the potential recycling of carbon dioxide. When carbon dioxide and water are combined in the photosynthetic processes, carbohydrates (sugars) that form the building blocks of biomass is produced and solar energy, that drives photosynthesis, is stored in the chemical bonds of the structural components of the biomass. If biomass is efficiently burned, oxygen from the atmosphere combines with the carbon in plants to produce carbon dioxide that is repeatedly available to produce new biomass [1].

Biomass is neutral in terms of CO<sub>2</sub> impacts, they emit as much CO<sub>2</sub> when burned as they had recently absorbed from the atmosphere the net effect is zero. Each year some 590-880 million tons of methane are emitted worldwide into the atmosphere through microbial activity [2]. About 90% of the emitted methane derives from biogenic sources (decomposition of biomass). Green house gases (GHGs) are: water vapor, CO<sub>2</sub>, CH<sub>4</sub>, N<sub>2</sub>O, HCFC, O<sub>3</sub>, PFC and HFC. CO<sub>2</sub> and CH<sub>4</sub> are the first and the second most important GHGs. Their contributions to the global warming are 61% and 15 % respectively [3], [4].

The environmental degradation associated with the current production and consumption of energy, particularly fossil fuels, threatens human health and quality of life and affects ecological balance and biodiversity. Currently, most of the greenhouse gases added to the atmosphere by human activities is carbon dioxide resulted from fossil fuel combustion. Photosynthesis by living plants and some bacteria can be

considered as highly efficient clean solar-energy conversion systems with [5], [6].

Waste-to-Energy and Solid Waste Management (SWM) is a "win-win" option as application of advanced waste management practices and techniques helps not only to reduce the quantity of wastes at source but also facilitates their treatment and disposal in environmentally friendly manner besides helping in generation of substantial amount of energy. With capacity of 3.5MW currently installed within Jordan, the utilization of biogas as a source of renewable energy makes a major contribution to the Jordan's commitment to tackling the issue of climate change [5], [6].

Biomass is a general term for all organic matter, which includes not only crops, wood, and marine products, but also organic wastes such as sewage sludge. Biomass is the only renewable organic resource that fixes atmospheric CO<sub>2</sub> by photosynthesis and does not break the CO<sub>2</sub> balance on a global scale. As one of the most abundant resources, biomass is an attractive and environmentally compatible energy source. Solid wastes originate from household, commercial, institutional and industrial practices contain significant proportions of organic materials. Organic waste is biodegradable and can be processed in the presence of oxygen by composting or in the absence of oxygen using anaerobic digestion. Both methods, when properly implemented, produce valuable source of nutrients that can be used in urban agriculture. Anaerobic digestion, in addition, produces methane gas, an important source of bio-energy. Anaerobic digestion can treat many biodegradable wastes, including wastes that are unsuitable for composting, such as meat and cooked food. Although this takes place naturally within a landfill, the term normally describes an artificially accelerated operation in closed vessels, resulting in a relatively stable solid residue [7].

Biogas plant is an efficient, well demonstrated technology for utilization of "pure" organic waste for production of electricity, heat energy and organic fertilizer without releasing greenhouse gas to the atmosphere. Biogases generated during anaerobic digestion (AD) are mostly methane and carbon dioxide. The introduction of the biogas as an alternative source of energy has found considerable acceptability in Jordan. This leads to methane emission reduction and produces clean renewable electricity and high quality fertilizer. Biogas burns with a clear blue flame has a temperature up to 800 °C and a calorific value 5650kcal/m<sup>3</sup>. Anaerobic digestion is the breakdown of organic material by micro-organisms in the absence of oxygen [7].

## 2. Background

Anecdotal evidence indicates that biogas was used for heating bath water in Assyria 3,000 years ago. The first digestion plant was said to have been built at a leper colony in Bombay, India in 1859. AD was first introduced in England in 1895, where biogas was recovered from a sewage treatment facility to fuel street

lamps in Exeter, Devon. In Germany in 1951, half the biogas from sewage sludge was converted for use as fuel for cars. AD has also been used to treat agricultural waste for several years and recently treats segregated municipal solid waste. Putrescibles and paper in household waste are ideally suited to anaerobic digestion.

Anaerobic digestion occurs naturally wherever high concentrations of wet organic matter accumulate in the absence of dissolved oxygen. This process is common in the bottom sediments of lakes and ponds, in swamps, peat bogs, intestine of animals and in the deep layers of landfill sites [8].

Anaerobic decomposition encountered several processes as specific bacteria feed on certain organic materials. In the initial stages, acidic bacteria dismantle the complex organic molecules into peptides, glycerol, alcohol and the simpler sugars. When these compounds have been produced in sufficient quantities, a second type of bacteria convert these intermediate products into hydrogen and carbon dioxide, which are then transformed into methane and water according to the equation (1):



These methane producing bacteria are particularly influenced by the ambient conditions, which can slow or halt the process completely if they do not lie within a fairly narrow band [8], [9].

Insoluble organic polymers such as carbohydrates, cellulose, proteins and fats are broken down and liquefied by enzymes produced by hydrolytic bacteria. Carbohydrates, proteins and lipids are hydrolyzed to sugars which then decompose further to form carbon dioxide, hydrogen, ammonia and organic acids. Proteins decompose to form ammonia, carboxylic acids and carbon dioxide [10]. During this phase gas concentrations may rise to levels of 80 per cent carbon dioxide and 20 per cent hydrogen. Organic acids formed in the hydrolysis and fermentation stage are converted by acetogenic micro-organisms to acetic acid. At the end of this stage carbon dioxide and hydrogen concentrations begin to decrease. Methanogenesis Methane (60%) and carbon dioxide (40%) are produced from the organic acids and their derivatives produced in the acidogenic phase. The methane is a useful fuel source and methanogenic bacteria play a further role in maintaining wider breakdown processes [1]. However, the overall process of anaerobic digestion occurs through a combined action of a consortium of different types of microorganism (Table 1).

The biogas production yield depends on the composition and biodegradability of the waste feedstock, but its rate of production depends on the population of bacteria, their growth conditions and the temperature of the process.

Table 1. Combined action of a consortium of different types of micro-organism.

Hydrolytic	Break down complex organic wastes into their components sub-units.
Fermentative	Transform these submits into short chains of fatty acids and carbon dioxide and hydrogen.
Syntrophic	Bacteria convert the short chains of fatty acids to acetic acid with release of heat, CO <sub>2</sub> and hydrogen.
Methane	Bacteria produce large quantities of methane and CO <sub>2</sub> from acetic acid, and combine the available hydrogen with CO <sub>2</sub> to produce more methane.
Sulphate-reducing	Bacteria reduce sulphates and other sulphur compounds to hydrogen sulphides. The hydrogen sulphides react with present heavy metals to form insoluble salts. Nevertheless, always is remaining some hydrogen sulphide.

### A. Biogas Development

Biogas is a gas mixture of methane, carbon dioxide and small quantities of hydrogen and hydrogen sulphide which is created under air exclusion through the fermentation of organic substances with microorganism assistance. Biogas mixture consists of approximately 40 to 75% methane (CH<sub>4</sub>), 25 to 60% carbon dioxide (CO<sub>2</sub>), and approximately 2% of other gases (hydrogen, hydrogen sulphide and carbon monoxide). The evaluation of input materials in a biogas process depends on their potential attainable yield. The biogas is a versatile source of energy, which is now preferably converted into electricity and heat. In recent years, several hundred biogas plants were taken in operation in Europe, where animal manure and organic wastes from industry and households are fermented [6], [11]. Apart from conventional materials, grass can also be fermented due to progress in the fermentation method. Farmers become "energy hosts" due to the fermentation of green material. The clean energy from grasslands can be easily transported and contributes to the reduction of greenhouse gases. Fermentation of grass can provide an ecologically and economically smart contribution to energy production of the future [12]. Figure 1 shows the different potential input material in the biogas systems with their corresponding biogas yield.

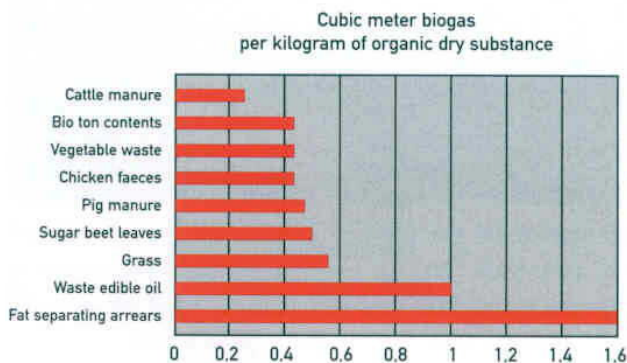

Fig. 1. Biogas Vs Organic dry Substances.

### B. General Factors Which Influence Biogas Production

The production of biogas is a natural process that functions in suited facilities. The following factors must be considered during biogas production:

- Organic input materials (substrates) should be biodegradable.
- Organic materials should contain only a minimum of microbiological restrictors (inhibitors).
- Temperature during decomposing process must be within the mesophilic range (optimum 35 to 55 °C). However, at thermophilic range (40–60 °C), the rate of decomposition is increased and less time is required for decomposition (12-14 hr). In low temperatures, bacterial activity slows down resulting in substantial decrease in gas generation, ceasing completely below 10 °C.
- The pH-value should range from 6 to 8.
- Fermentation must take place in an area sealed off from air and light.
- Fermentation tank must be mixed at regular intervals.
- Carbon-nitrogen ratio of the feed material should be in the range of 20:1 to 30:1. Solid concentration in the feed material should be between 8 and 10 % to ensure sufficient gas production as well as easy mixing and handling.

### C. Desulphurization of the Biogas

The quality of the biogas produced from AD affects its final usefulness. The main concern in this context is the presence of hydrogen sulphide which occurs as a metabolic bi-product of sulphur-reducing bacteria in the digester. Hydrogen sulphide can rapidly corrode the gas-handling and electricity generating equipment in the plant. Cleaning of the biogas is therefore recommended because of the very corrosive effect of hydrogen sulphide (H<sub>2</sub>S). In principle, there are two basic procedures: absorption of hydrogen sulphide by ferric oxide and microbial desulphurization by the addition of air. In the later process, about 4% of the surrounding air is injected to reduce the hydrogen sulphide to elementary sulphur by bacterial action. The sulphur simply turns into precipitation.

### D. Biogas Vs Energy

The part of biogas which can be used for energy production is methane. In combined heat-to-power-couplings, it is converted into electricity and heat. The overall efficiency of the energy is about 80 to 90 %. Heat is used directly for the heating of accommodations or for warm water supply. In some cases it can also be supplied to a close or a long-distance heating network. The mechanical power generated by the processing of the biogas in the combined heat-to-power-couplings is converted into electricity by generators. Electricity is used for powering the facilities and is fed to the public power supply system. Profits from local power suppliers

are an additional source of income for many operators of biogas plants. Biogas can also be supplied directly via pipelines into a biomass heating plant. By doing so, the user can avoid the implementation of an oversized boiler and the installation of an additional heat source [13], [14]. Methane is a greenhouse gas thirty times more damaging than the equivalent amount of carbon dioxide. If one tone of putrescible food waste consists of 77 per cent water and 23% solids, the digester will convert approximately 75% of the solids to biogas. The maximum possible yield of biogas is 400 m<sup>3</sup>, however, in practice it is nearer to 100 m<sup>3</sup>. This has an energy value of around 21-28 MJ/m<sup>3</sup>. Between 20-50% of the energy produced will be used to run the plant. Biogas may be used directly or as a replacement fuel for kilns, boilers and furnaces located close to the AD site. If the gas is used in power generation, gas clean-up is required to remove corrosive trace gases, moisture and vapors [15], [16].

The modern anaerobic digestion treatment processes are engineered to control the reaction conditions to optimize digestion rate and fuel production. Hydraulic Retention Time (HRT) refers to the number of days the feed material is required to remain in the digester to begin gas production. HRT is the most important factor in determining the volume of the digester which in turn determines the cost of the plant. The larger the retention period, the higher the construction cost. Digesters have a number of advantages compared to untreated MSW for the near-by community and the environment alike. At the biogas plant controlled sanitation of the MSW takes place, i.e. bacteria, viruses and weed seeds are killed [17], [18].

### 3. Jordan Biogas Plant

The biogas plant in Jordan receives daily 60 tons of pure organic waste consists mainly of:

1. Slaughterhouse waste.
2. Food waste from restaurants & hotels.
3. The central market for vegetables.
4. Blood.
5. Yeast wastewater, dairy industry wastewater.

The digester is fed with a mixture of liquid waste and organic waste, called "slurry." Inside the digester, each daily load of fresh slurry flows in one end and displaces the previous day's load which bacteria and other microbes have already started to digest. Each load progresses down the length of the digester to a point where the methane bacteria are active. At this point, large bubbles force their way to the surface where the gas accumulates. The gas is very similar to natural gas and is burned directly for internal combustion power engines. The pilot plant consists of the followings (Figure 2):

- 1) Solid waste receiving and inspection
- 2) Liquid waste receiving: The capacity of the storage tank is 300 m<sup>3</sup> to receive liquid waste
- 3) Waste conveying through a screw conveyor.

4) Mixing tank: the waste is mixed up to form homogenized pumpable slurry with 10 % total solids. The slurry is pumped through screw pumps to the reactor where an anaerobic condition is established. The temperature is maintained by heating the incoming slurry through heat exchanger that uses the cooling water for gas engine to heat the slurry.

5) Reactor: the slurry is pumped through screw pumps to the reactor where an anaerobic condition is established (Temperature of 36 °C, HRT 25 days). The temperature is maintained by heating the incoming slurry through heat exchanger that uses the cooling water for the internal combustion engine to heat the slurry. The biogas is collected from the upper dome of the reactor.

6) Separator: the digested slurry is pumped out from the reactor to the separator where it is separated into liquid and solid (compost). The chemical analysis of the compost has shown good results regarding NPK contents which make it a good soil conditioner and fertilizer.

7) Storage Tanks: the separated liquid compost is pumped after the separator to the storage tanks (1600 m<sup>3</sup> and 100 m<sup>3</sup>). The liquid is used to humidify and providing the bacteria in the desulphurizing unit with the nutrients necessary for their activity and growth.

8) Gas cleaning: the gas cleaning system consists of two steps: removal of H<sub>2</sub>S through a biofilter: The biofilter is a cylindrical Tank (80 m<sup>3</sup>) filled with plastic packing and special bacteria growing on this packing which are capable of oxidizing the H<sub>2</sub>S into free sulfur. A stream of liquid compost is circulated around the packing to provide the bacteria with the nutrients and humidity.

9) Gas drying through a condenser cooler: The biogas in this step is cooled down by refrigeration and condensed water is drawn out of the gas.

10) Gas Storage: the biogas is stored temporarily in this tank (1200 m<sup>3</sup>), the tank is equipped with plastic membrane to control gas pressure, and the pressure of biogas is boosted up to 70 mbar by a mean of gas booster before the gas- engine.

11) Electricity production: the gas is utilized through a gas engine generator set to produce 3.5 MW of electrical power.

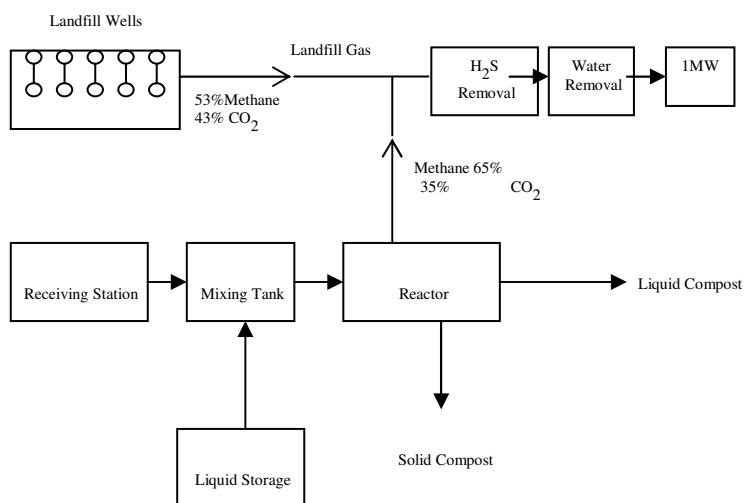

Fig. 2. The Biogas Plant in Jordan.

This plant also consists of 100 gas extraction wells. These wells are drilled in the closed Russaifeh landfill. The wells consist of pipe (DN 125) inserted in a borehole, where 70 % of the pipe length is perforated to enhance gas collection. The pipes are peripherally supported by gravel, bentonite and sand packing. From each well a secondary pipeline is connected to a main pipeline transport the gas to a control container. The gas collection is achieved by applying a suction pressure to the wells through a blower that sucks the gas and deliver it to the gas cleaning system. The overall objective of the biogas project is to develop and disseminate biogas as a mainstream renewable energy technology in Jordan and the region. The project aims at:

- Raising awareness of municipal sectors to enhance their capability to manage and convert organic wastes into valuable products in a sustainable manner.
- Developing and replicating the biogas projects to reduce greenhouse emissions significantly.

#### 4. Results

The biogas project has assessed the socio-economic and environment impacts of using biogas as a sound energy and fertilizer benefits and preventing many common problems that have negative impacts. The system looks forward to maximize the use of resources by the application of appropriate technology. The Russaifeh landfill dumping site was originally an old phosphate mine located between the major two big cities of Amman and Zarka. Deposition of waste in unsanitary land filling causing severe environmental problems such as emissions of greenhouse gases (GHG) and other substances, toxic residuals, potential contamination of ground water, pollution of the waterways, odor and bad smell as well as possible fires and explosions due to the release of methane gas. The installation of this project has changed the whole situation were many negative impacts have been eliminated. The pilot biogas plant has contributed heavily to solve major environmental and social problems. The biogas technology is considered as an efficient solution for serious local environmental problems.

The Plant has a significant effect on the socio-economic aspects of sustainable development and will be assisting Jordan towards meeting its Kyoto obligations by achieving significant fossil fuel savings and to convert organic waste as a renewable energy source and to get benefit from other by-products such as composting and recycling. The following lessens have been achieved:

- Landfill gases must be controlled for as they are expected to be generated.
- The system adopted at Amman plant proved to be successful and could be adopted in other Middle East countries.
- Biogas exploitation has triple benefits as important renewable energy source, improving the environment and the beneficial value of the bio

fertilizer production. A top quality fertilizer that guarantees better crops.

- It is also possible to apply small biogas energy and fertilizer supply systems in the rural and urban areas to improve the standard of living and reduce burden being imposed on women and children
- Degassing and stabilizing of municipal organic solid waste through anaerobic treatment is widely used technology in the developed countries, implementation of this technology in Amman proved to be successful.
- It has been realized that the role of the private sector is possible.
- The installation of the biogas project has changed the whole situation were many negative impacts have been eliminated. The pilot biogas plant has contributed heavily to solve major environmental and social problems.

#### *Biogas Potential in Jordan*

In terms of quantity per capita and constituents, the waste generated in Jordan is comparable to most semi-industrialized nations. The per capita of waste generated in Jordan is about 0.9 kg/day. The total generation of waste in Jordan is estimated at 3.5 million tons per year. The composition of the waste generated is shown in Table 2.

Table 2. Biogas Potentials in Jordan.

Component	% by weight
Organic Matter	55
Paper	23
Plastics	13
Textile	2
Metals	2.5
Glass	3

The main resources of organic waste in Jordan that can be potentially used to produce biogas are summarized as follows:

- Municipal waste from big cities (1.5 million tons per year) mainly from slaughterhouse, vegetable market, hotels and restaurants.
- Organic waste from agricultural and industrial waste including meat – processing industries.
- Animal manure, mainly from cows and chickens.
- Sewage sludge and septic.
- The olive mills.
- Other organic industrial waste sources including fermentation industries, chemical and pharmaceutical industries.

Table 3 shows the generated organic waste in Jordan according to the study conducted by the Greater Amman Municipality in 2009. In addition, an annual amount of 1.83 million cubic meter of septic and sewage sludge from treatment of 44 million cubic meter of sewage water is generated in greater Amman area. The potential annual sewage sludge and septic generated in Amman can be estimated at 85,000 tons of dry matter.

Table 3. The Quantities of Organic Waste Generated in Jordan (Tons).

Slaughterhouses	16,060
Vegetable market	10,950
Hotels	10,950
Restaurants	43,800
Tanneries	370
Eating oil refineries	1,100
Sesame oil	4,380
Meat processing	370
Canneries	12,050
Dairies	3,300
Vegetable farms	208,000
Olive oil mills	50,000
Chicken manure	350,000
Cow manure	800,000

## 5. Conclusion

From the environmental perspective, the treatment of waste represents the ultimate solution to the pollution and odor problems that threaten the population and the ecosystem at both local and global levels. Biogas plant has been reasonably successful in Jordan in providing clean and renewable source of energy. The use of biomass energy has many unique qualities that provide environmental benefits.

## References

- [1] M. Kurihara, T. Magner, R.A. Hunter and G.J. McCrabb, "Methane production and energy partition of cattle in the tropics", *British Journal of Nutrition*, 1999, Vol. 81, pp. 227-234.
- [2] R. Leuning, S.K. Baker, I.M. Jamie, C.H. Hsu, L. Klein, O.T. Denmead and D.W.T. Griffith, "Methane emission from free-ranging sheep: a comparison of two measurement methods", *Atmos. Environ.*, 1999, Vol. 33, pp.1357–1365.
- [3] E.A. Hoffa, D.E. Ward, W.M. Hao, R.A. Susott and R.H. Wakimoto, "Seasonality of carbon emissions from biomass burning in a Zambian savanna", *J. Geophys. Res.*, 1999, Vol. 104, pp. 13841-13853.
- [4] IPCC, Intergovernmental Panel on Climate Change, "Good practice guidance and uncertainty management in National Greenhouse Gas Inventories. National Greenhouse Gas Inventories Programme", Institute for Global Environmental Strategies, 2000, Japan.
- [5] IPCC, Intergovernmental Panel on Climate Change, "IPCC Guidelines for National Greenhouse Gas Inventories", 1997, IPCC/OECD/IEA, Paris, France.
- [6] C.R. Engler, E.R. Jordan, M.J. McFarland., R.D. Lacewell, "Economics and environmental impact of biogas production as a manure management strategy", in *Proceedings of the 1999 Texas Animal Manure Management Conference*, 1999, Texas A & M University. College Station, TX, USA.
- [7] P. Börjesson, "Energy analysis of biomass production and transportation", *Biomass and Bioenergy*, 1996, Vol. 11, pp. 305–318.
- [8] I.D. Cowley and D.A. Wase, "Anaerobic digestion of farm waste: a review", *Process Biochemistry*, 1981, Vol. 16, No. 5, pp. 28–33.
- [9] K.L. Kunsch, "Cooperative anaerobic digestion as a manure management alternative for Northeastern Wisconsin", 2003, M.Sc. Thesis. University of Wisconsin, Green Bay, WI, USA.
- [10] W.J. Jewell, P.E. Wright, N.P. Fleszar, G. Green, A. Safinski and A. Zucker, "Evaluation of Anaerobic Digestion Options for Groups of Dairy farms in Upstate New York", Department of Agriculture and Biological Engineering, Cornell University, 1997, Ithaca, NY, USA.
- [11] P.D. Lusk, "Methane Recovery from Animal Manures: The Current Opportunities Casebook", National Renewable Energy Laboratory US Department of Energy, 1998, Washington, DC.
- [12] B.B. Brown, E.K. Yiridoe and R. Gordon, "Impact of single versus multiple policy options on the economic feasibility of biogas energy production: swine and dairy operations in Nova Scotia", *Energy Policy*, 2007, Vol. 35, pp. 4597–4610.
- [13] I.H. Rowlands, D. Scott and P. Parker, "Ready to go green? The prospects for premium-priced green electricity in Waterloo region", *Ontario, Environments*, 2000, Vol. 28, No. 3, pp. 97–119.
- [14] A.F. Bouwman, "Direct emissions of nitrous oxide from agricultural soils", *Nutrient Cycling in Agroecosystems*, 1996, Vol. 52, pp. 165-170.
- [15] C.G. Gunnerson and D. V. Stuckey, "Integrated Resource Recovery-Anaerobic Digestion-Principles and Practices for Biogas systems", 1986, World Bank Technical Paper No. 49.
- [16] H. Clayton, I.P. McTaggart, J. Parker, L. Swan and K.A. Smith, "Nitrous oxide emissions from fertilized grassland: A 2-year study of the effects of fertilizer form and environmental conditions", *Biology and Fertility of Soils*, 1997, Vol. 25, pp. 252-260.
- [17] F.W. Welsh, D.D. Schulte, E.J. Krockner and H.M. Lapp, "The effect of anaerobic digestion upon swine manure odors", 1977, *Canadian Agricultural Engineering*, Vol. 19, No. 2, pp. 122–126.
- [18] K.Y. Emmanuel, G. Robert and B.B. Bettina, "Non-market co-benefits and economic feasibility of on-farm biogas energy production", 2009, Vol. 37, No. 3, pp. 1170-1179.