

RISØ-M-2524

RESEARCH AND STANDARDIZATION ACTIVITIES OF THE
EURATOM NEUTRON RADIOGRAPHY WORKING GROUP

J.C. Domanus

Abstract. Following a general review of the functions of the Euratom Neutron Radiography Working Group (NRWG) details about the achievements, work in progress and future activities of this group are presented. A classification of neutron radiographic findings in reactor fuel is given and reference neutron radiographs that are prepared according to this classification are reviewed.

Indicators for the control of neutron beam components and radiographic image quality control are described.

The use of calibration fuel pin and the problem of dimensional measurements from neutron radiographs are discussed. Some details are given on the NRWG Test Program, work on nitrocellulose film and terminology.

(Continued on next page)

September 1985

Risø National Laboratory, DK-4000 Roskilde, Denmark

This report has been accepted for presentation at the International Atomic Energy Agency's Seminar on Applied Research and Service Activities for Research Reactor Operations (Copenhagen, Denmark, 9-13 September 1985).

INIS Descriptors: EURATOM; NEUTRON RADIOGRAPHY; NUCLEAR FUELS;
RESEARCH PROGRAMS

ISBN 87-550-1147-0

ISSN 0418-6435

Grafisk Service Center, Risø 1985

CONTENTS

	Page
1. INTRODUCTION	1
2. NEUTRON RADIOGRAPHIC FINDINGS IN REACTOR FUEL	3
3. RADIOGRAPHIC QUALITY STANDARDS	5
4. CALIBRATION FUEL PINS	10
5. DIMENSIONAL MEASUREMENTS	10
6. NRWG TEST PROGRAM	11
7. NITROCELLULOSE FILM	14
8. TERMINOLOGY	14
9. FUTURE WORK OF THE NRWG	15
REFERENCES	16

ILLUSTRATIONS		Page
Fig.1.	Examples of nuclear fuel pins	4
Fig.2.	BPI (left) and BPI-F (right)	6
Fig.3.	ASTM SI	7
Fig.4.	AFNOR IQI	8
Fig.5.	CFP-E1	9
Fig.6.	Thickness , radiation intensivity and film density for a fuel pin	12
Fig.7.	NRWG Test Program	13

1. INTRODUCTION

Neutron radiography, a well-established technique within non-destructive testing control, is used mainly in pre- and especially post-irradiation control of nuclear reactor fuel.

It is felt that standardization is also needed in this field for methods and procedures to control the radiographic image as well as produce standard reference neutron radiographs of reactor fuel. Such standards do exist in other fields of industrial radiography.

To fulfil that need a Neutron Radiography Working Group (NRWG) was constituted within Euratom in May 1979. This group, to which all the neutron radiography centers within the European Community belong, deals mainly with the following problems related to neutron radiography of nuclear reactor fuel:

- Image quality of neutron radiographs.
- Classification of defects revealed by neutron radiography and showing them on standard reference radiographs.
- Recommended practices for neutron radiographic testing.
- Accuracy of dimensional measurements from neutron radiographs.
- Terminology used in neutron radiography of nuclear fuel.

To solve particular problems in the above fields specialised sub-groups are formed within the NRWG. General progress achieved and future plans of work are reported and drafted at annual meetings of the NRWG, whereas the sub-groups of the NRWG meet when needed.

The work in the field of reference neutron radiographs was initiated at Risø National Laboratory in 1979, when the first classification of defects and a collection of radiographs illustrating those defects [1] was published.

A special sub-group, created for producing of a larger, revised

edition of this atlas, has issued such an atlas [2] on that subject in 1984.

In 1981 a "Neutron radiography handbook" [3] was published by the NRWG.

Besides describing the principles of neutron radiography the handbook contains recommended practices in the field and describes neutron radiography indicators, defects revealed by neutron radiography and the neutron radiography installations in the European Community.

Now a special sub-group of the NRWG 's working on a second, revised edition of the Handbook. It will be published in 1986 under the title "Practical neutron radiography".

Special attention of the NRWG is given to the use of nitrocellulose film for neutron radiography of nuclear reactor fuel. Many problems in this field are still unsolved.

Therefore, a special sub-group of the NRWG is working on a report on "Neutron radiography on nitrocellulose film".

It is intended to publish this report just before the Second World Conference on Neutron Radiography (Paris, June 1986).

Another important problem in the field of neutron radiography of nuclear reactor fuel is the accuracy with which the dimensions can be measured from neutron radiographs. A special sub-group of the NRWG is dealing with this problem.

While reviewing the current activities of the NRWG it is worth mentioning that an "International Neutron Radiography Newsletter (INRNL) is published currently in the British Journal of Non-Destructive testing. It keeps all those concerned informed about the activities of different centers and organizations in the field of neutron radiography.

The members of the NRWG have greatly contributed to the First World Conference on Neutron Radiography [4] and are now active

on preparing the second conference in that field.

2. NEUTRON RADIOGRAPHIC FINDINGS IN REACTOR FUEL

As mentioned above, in the collection of reference neutron radiographs of nuclear reactor fuel [2] classification was given of different findings on neutron radiographs of nuclear fuel. This classification is listed below:

- | | |
|-----------------------------------|--------------------------------|
| 0. (Fuel pin parts) AS FABRICATED | 3. CHANGE OF SHAPE OR LOCATION |
| 1. CRACKS | 3.1 Enlarged or swollen |
| 1.1 Random | 3.2 Contracted |
| 1.2 Longitudinal | 3.3 Filled-up or closed |
| 1.3 Transverse | 3.4 Deformed |
| 1.4 Annular | 3.5 Broken |
| 1.5 Stratified | 3.6 Dislocated |
| | 3.7 Extended |
| 2. CHIPS | 3.8 Accumulated |
| 2.1 Corner | 3.9 Restructured |
| 2.2 Other | 3.10 Melted |
| 2.3 In pellet-to-pellet gap | 3.11 Disintegrated |
| 2.4 Missing | 3.12 Migrated |
| | |
| 4. VOIDAGE | 6. CORROSION |
| 4.1 In one pellet | 6.1 Hydrides |
| 4.2 Through several pellets | 6.2 Oxides |
| 4.3 Through whole fuel column | 6.3 Other |
| | |
| 5. INCLUSIONS | 7. NUCLEAR PROPERTIES |
| 5.1 Of Plutonium | 7.1 Different enrichment |
| 5.2 Of poison | 7.2 Different burn-up |
| | |
| | 8 COOLANT |
| | 8.1 Present |
| | 8.2 Absent |

Some typical examples of nuclear fuel pins, where those findings can be found, are shown in fig.1. They represent pelletized, annular and vibro-compacted fuel.

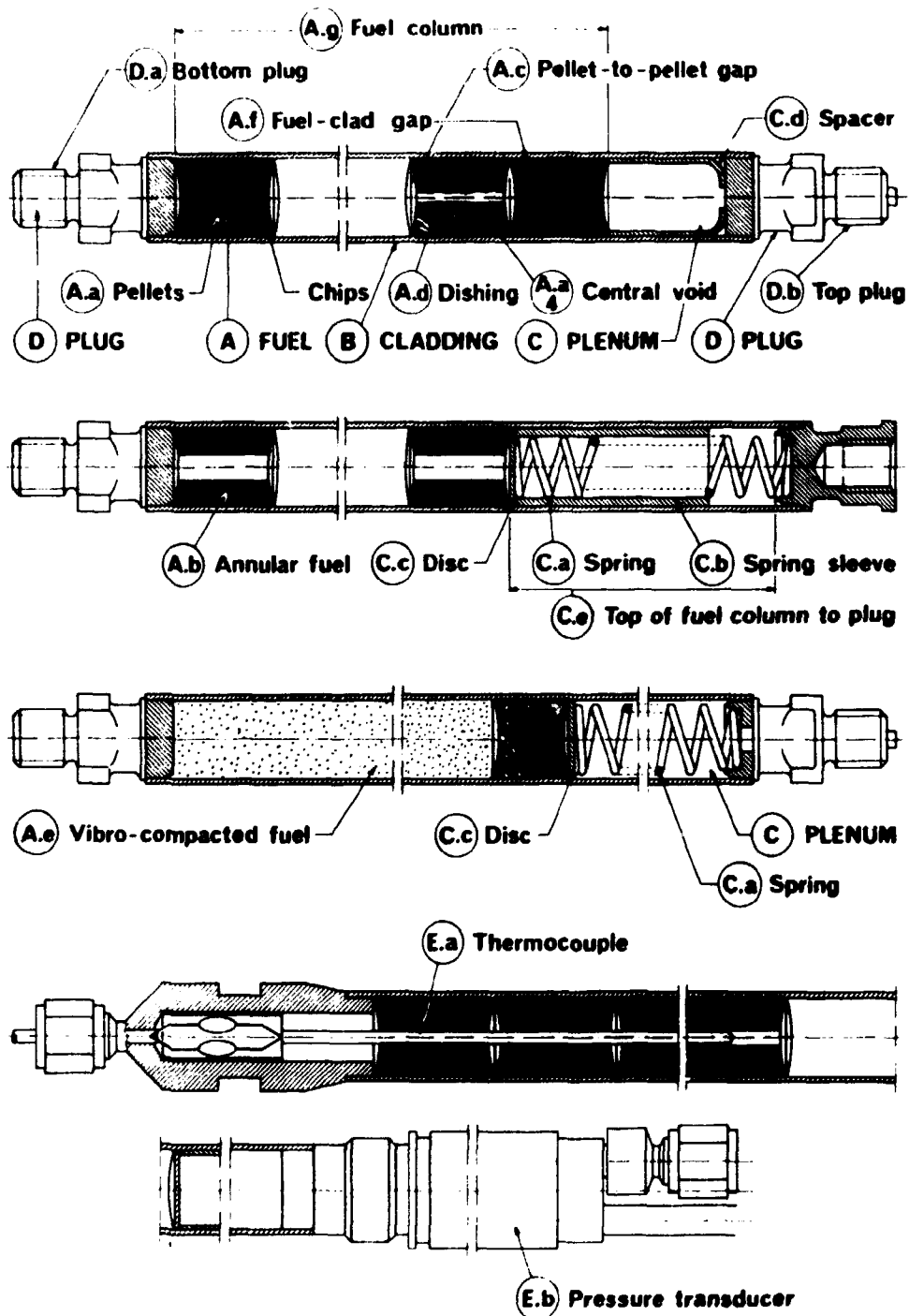

Fig. 1 Examples of nuclear fuel pins

The collection of neutron radiographic findings [2] contains 158 radiographs, reproduced in their original size on duplicating film and twice enlarged on photographic paper.

3. RADIOGRAPHIC QUALITY STANDARDS

To be able to establish radiographic quality standards in the field of neutron radiography of nuclear fuel it was necessary to perform some research on the design and performance of neutron beam and neutron image quality indicators. As neither national nor international standards exist in this field, the ASTM indicators (designed for neutron radiography at large [5]) and the AFNOR image quality indicator [6] (for non-radioactive items) are tested together with a special indicator for nuclear reactor fuel. This is done under the NRWG Test Program.

To check the neutron beam components a beam purity indicator (BPI) is used, as well as a modified beam purity indicator for nuclear fuel (BPI-F). They are shown in fig. 2.

To determine the sensitivity of detail visible in the neutron radiograph a sensitivity indicator (SI) is used (see fig. 3).

By using the BPI (or BPI-F) and the SI one can determine the image quality of a neutron radiograph according to the method prescribed by ASTM E545 [5]. This method was designed for neutron radiography using silver halide film. It is under revision now and in the future will be limited only to the direct method of neutron radiography.

To control the quality of neutron radiographs of non-radioactive items an AFNOR image quality indicator (IQI) may be used [6]. It is shown in fig.4.

BEAM PURITY INDICATOR **BPI**

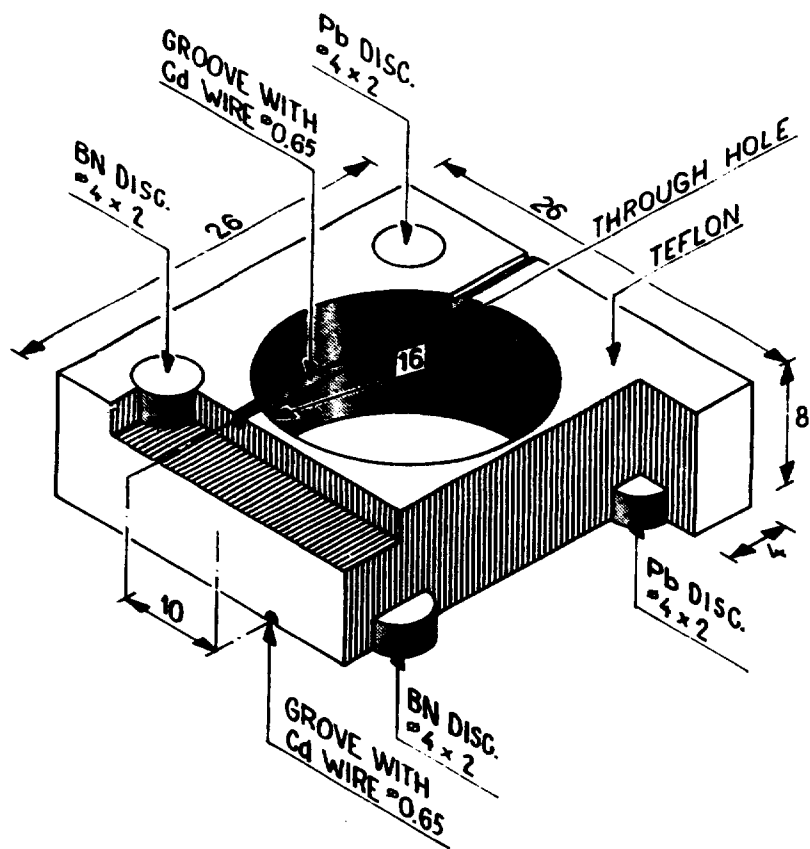

RISØ

BEAM PURITY INDICATOR-FUEL **BPI-F**

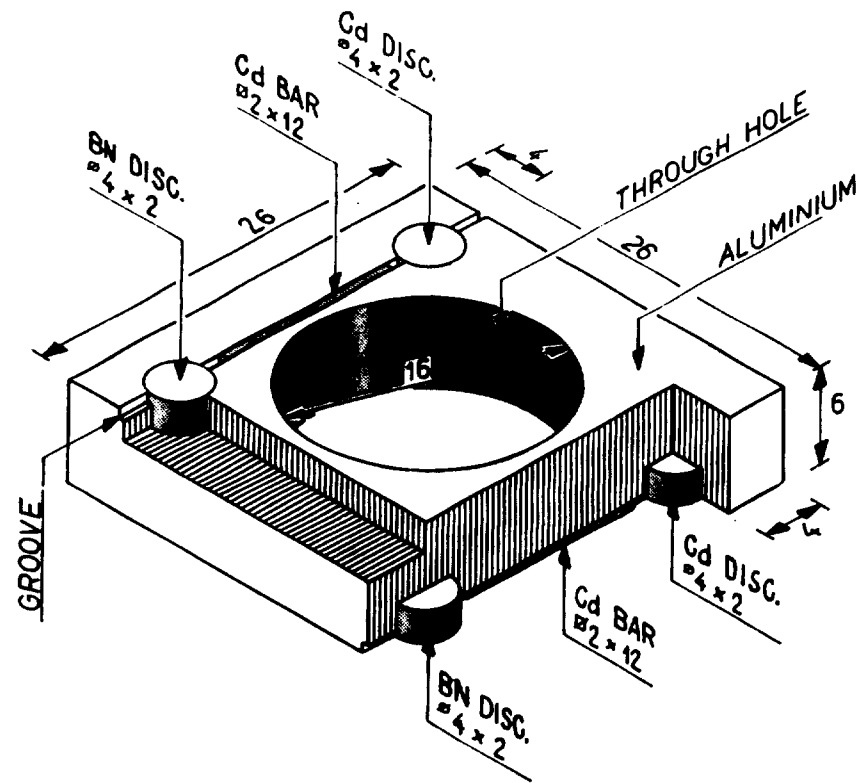

RISØ

Fig. 2. BPI (left) and BPI-F (right)

SENSITIVITY INDICATOR SI

RISØ

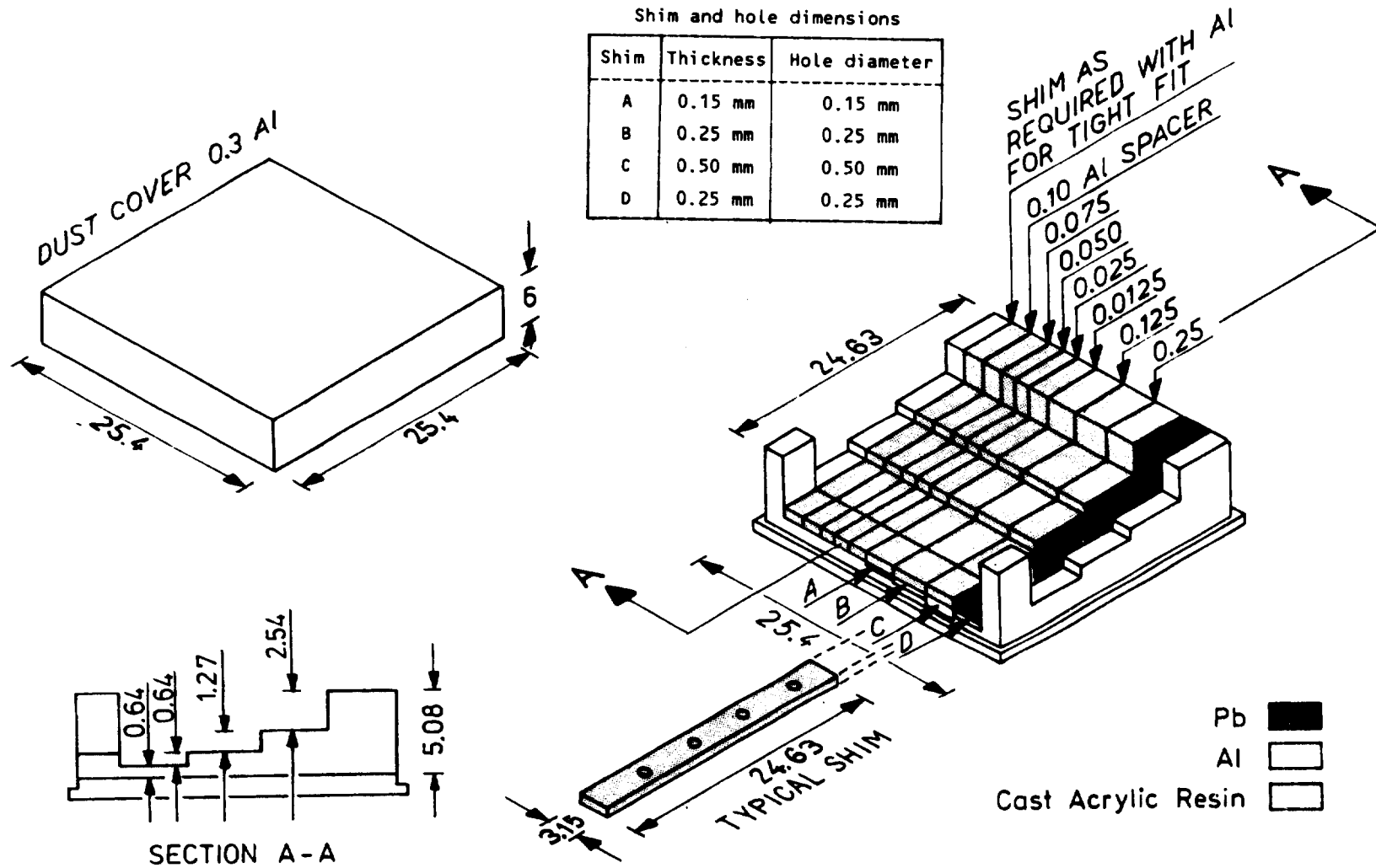

fig. 3. ASTM SI

Calibration fuel pin CFP-E1

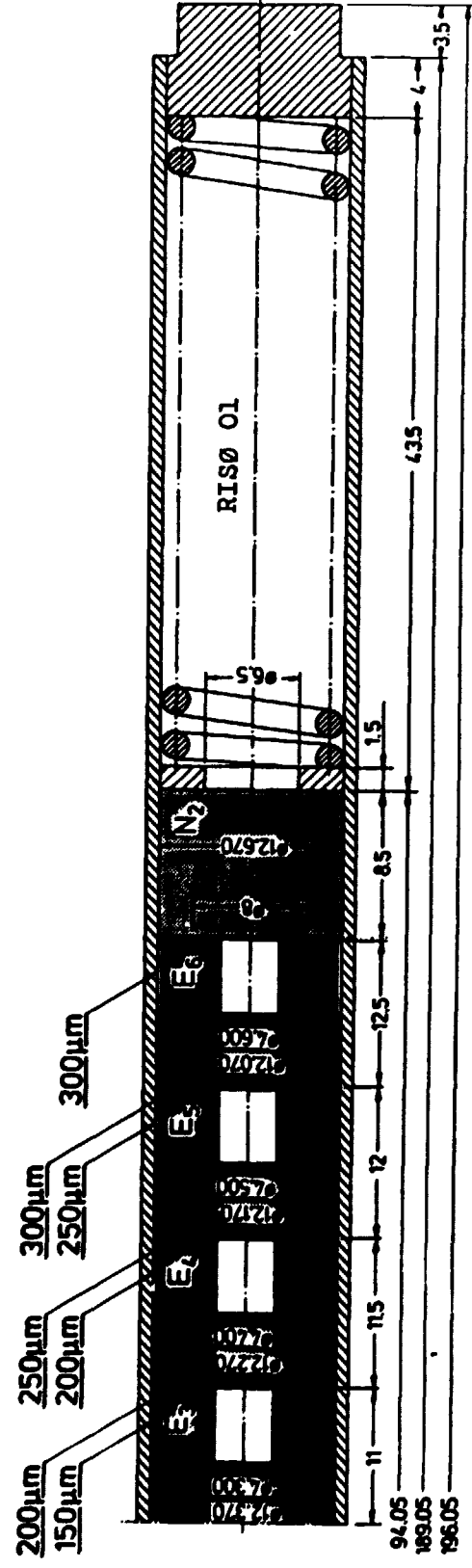
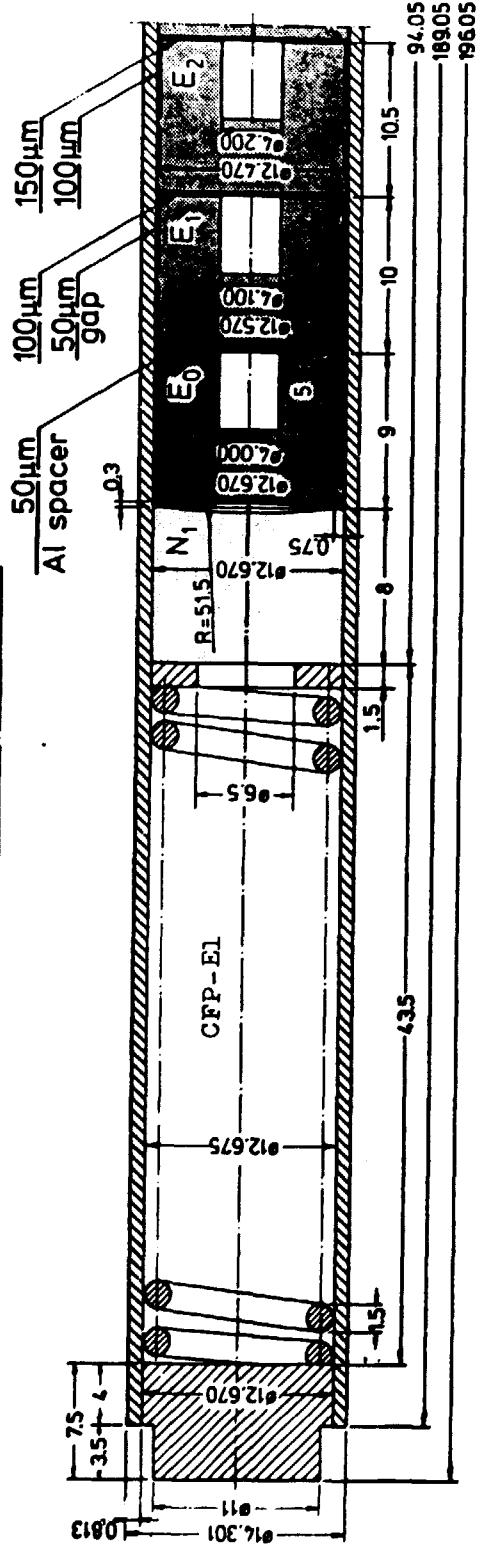

Fig. 5. CFP-E1

4. CALIBRATION FUEL PINS

As none of the radiographic image quality indicators described above were designed especially for neutron radiography of nuclear reactor fuel, following the recommendation of the ASTM standard [5] a special "reference standard comparison part" was developed at Risø National Laboratory. This is the calibration fuel pin CFP-E1 shown on fig. 5. It includes such "standard discontinuities" as pellet-to-pellet and pellet-to-cladding gaps (calibrated gaps from 50 to 300 μm) and calibrated central void.

By visually examining those gaps on neutron radiographs of the calibration fuel pin one can draw conclusions about the radiographic quality of the radiogram.

The CFP-1 is also used for assessing of the accuracy of dimensional measurements from neutron radiographs, as described below.

5. DIMENSIONAL MEASUREMENTS

By the use of the calibration fuel pin (see fig. 5) not only can the quality of the neutron radiographic image be assessed, but also the accuracy of dimensional measurements from neutron radiographs can be tested. Those measurements are necessary to judge the behaviour of nuclear fuel pins after irradiation in a reactor by assessing the dimensional changes occurring in the fuel itself and the cladding, and comparing this information with the preirradiation measurements. To extract this information from neutron radiographs, one must have an accurate method of measuring dimensions on the films on which neutron radiographs are taken.

Although it is comparatively easy to see even minute changes in dimensions on neutron radiographs, it is very difficult to measure them accurately. This problem was investigated at Risø

using different measuring techniques and is now under investigation by the NRWG.

In principle all the dimensions can be read from neutron radiographs in terms of distances between maximum and/or minimum optical film densities, as shown, e.g. in fig 6 for a fuel pin. It is, consequently, a length measurement

6. NRWG TEST PROGRAM

The NRWG has developed a test program for checking the image quality and accuracy of dimensions measured from neutron radiographs of nuclear fuel pins. For that program indicators described above (BPI, BPI-F, SI) and a calibration fuel pin (CFP-E1) are used. They are neutron radiographed together at each of the NR facilities participating in the NRWG. Silver halide X-ray films are exposed with Gd and Dy converters by the direct and transfer method. Nitrocellulose film is also used; it is coated on both sides with a converter and without coating but between two converter screens. The radiographs are thereafter processed at the centers themselves, and another set of identical radiographs centrally at Risø.

Altogether 30 visual evaluations, film density and dimensional measurements are being done for each set of neutron radiographs taken at each NR facility, as shown on fig. 7.

Neutron beam constituents are calculated from the radiographs of the BPI and BPI-F; the sensitivity levels are found from the SI, and from the CFP-E1 the image quality and accuracy of dimensional measurements are determined.

Although the AFNOR standard [6] is designed for neutron radiography of non-radioactive parts, the gadolinium-slit-IQI described there seemed interesting enough to be tested along with the other test objects of the NRWG test program. Therefore the Gd IQI is circulating now among the NRWG members and will be evaluated later.

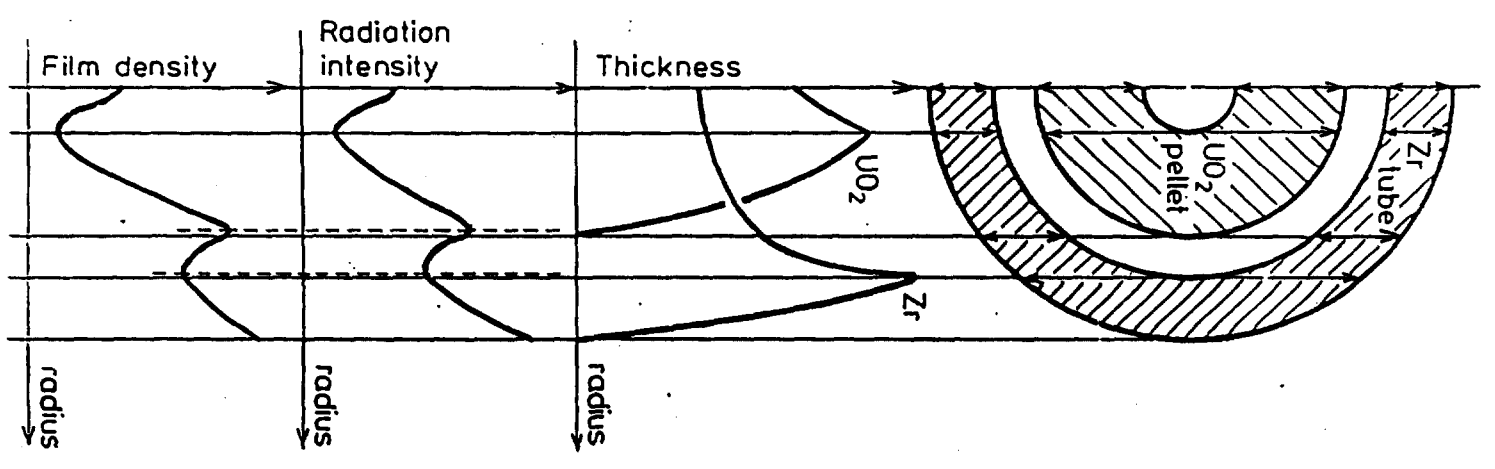

Fig. 6. Thickness, radiation intensity and film density

NRWG TEST PROGRAM

	Processed at																	
	NR center								RISO									
Converter	Gd			Dy			B	BN1	Gd			Dy			B	BN1		
Film	SR	D4	M	SR	D4	M	CNB	CN	SR	D4	M	SR	D4	M	CNB	CN		
Code No	1	3	5	7	9	11	13	22	2	4	6	8	10	12				
Etched at													20°C	50°C	20°C	50°C		
Code No													16	19	25	28		
Copy on							S0015								S0015			
Code No							14	23							17	20	26	29
Viewed through	Polarizing filters																	
Code No							15	24							18	21	27	30

Fig. 7. NRWG Test Program

7. NITROCELLULOSE FILM

As mentioned before, there are many problems to be solved in connection with the use of nitrocellulose film for neutron radiography of irradiated nuclear fuel. The advantages of using this technique stand out most exactly in that field : nitrocellulose film being insensitive to gamma rays and light can be used directly for radiography of radioactive objects and it produces a sharper image than on silver halide film.

The optimum conditions for obtaining a neutron radiograph on nitrocellulose film of highest radiographic quality depends on the following factors: neutron fluence, time and temperature of the etching bath, its composition and concentration as well as the use of different neutron-to-alpha converters.

The use of nitrocellulose film is included into the NRWG Test Program (see fig. 7). There, the assessment of the neutron radiographic image obtained on nitrocellulose film will be done either directly from nitrocellulose film, from its copy on a high-contrast duplicating film or by means of viewing between polarizing filters.

These viewing methods are also to be considered in relations to the use of the nitrocellulose film for neutron radiography.

The above-mentioned various aspects of use of the nitrocellulose film will be described in a special report prepared by a NRWG sub-group on nitrocellulose film.

8. TERMINOLOGY

The first step toward establishing a common terminology to be used for neutron radiography was made in 1981 when the Neutron Radiography Handbook [3] was published.

It contains some basic terms and definitions in that field.

This collection of terms and definitions will be greatly enlarged in the "Practical neutron radiography" (enlarged edition of the Handbook).

The use of a common, tantamount terminology is especially important for assessing neutron radiographic findings. Therefore, in the atlas of reference neutron radiographs [2] (written both in English and in French) a special chapter is devoted to terminology. There the terms used throughout the classification along with other useful terms are given in English, Danish, German, French, Italian and Dutch.

9. FUTURE WORK OF THE NRWG

At present three sub-groups are acting within the NRWG. The sub-group on nitrocellulose film intends to publish a special report on that subject just before the Second World Conference on Neutron Radiography (Paris, June 1986).

The sub-group on neutron radiography handbook intends to publish its new edition at the end of 1986 under the title: "Practical neutron radiography".

The sub-group on measurements is testing the AFNOR IQI and will do the same with a simplified device to measure the L/D ratio in neutron radiographic facilities.

The NRWG Test Program, performed now with the participation of all NRWG members, will be terminated in 1986 and by the end of that year Risø will present a final report about it.

REFERENCES

- 11** **DOMANUS J.C.:** Neutron radiographic findings in light water reactor fuel. Metallurgy Department. Risø National Laboratory, June 1979.
- 12** **DOMANUS J.C. (editor).** Reference neutron radiographs of nuclear reactor fuel. D. Reidel Publishing Company. Dordrecht/Boston/Lancaster. 1984.
- 13** **von der HARDT P., RÖTTGER H. (editors):** Neutron radiography handbook. D. Reidel Publishing Company. Dordrecht/Boston/London. 1981.
- 14** **BARTON J.P., von der HARDT P. (editors):** Neutron radiography. Proceedings of the First World Conference. San Diego, CA, USA. 7-10.12.1981. D. Reidel Publishing Company. Dordrecht/Boston/London, 1983.
- 15** **ASTM E545-81.** Standard method for determining image quality in thermal neutron radiographic testing.
- 16** **AFNOR A09-22.** Industrial neutron radiography. Determination of the characteristics of testing facilities for the control of non-radioactive parts. September 1982.

2524

Rise - M -

<p>Title and author(s)</p> <p>Research and Standardization Activities of the Euratom Neutron Radiography Working Group</p> <p>J. C. Domanus</p>	<p>Date 1985-08-05</p>
<p>16 pages + 0 tables + 7 illustrations</p>	<p>Department or group</p> <p>Metallurgy</p>
<p>Abstract</p> <p>Following a general review of the functions of the Euratom Neutron Radiography Working Group (NRWG) details about the achievements, work in progress and future activities of this group are presented. A classification of neutron radiographic findings in reactor fuel is given and reference neutron radiographs that are prepared according to this classification are reviewed.</p> <p>Indicators for the control of neutron beam components and radiographic image quality control are described.</p> <p>The use of a calibration fuel pin and the problem of dimensional measurements from neutron radiographs are discussed. Some details are given on the NRWG Test program, work on nitrocellulose film and terminology.</p> <p>This report has been accepted for presentation at the International Atomic Energy Agency's Seminar on Applied Research and Service Activities for Research Reactor Operations (Copenhagen, Denmark, 9-13 September 1985).</p> <p>Available on request from Rise Library, Rise National Laboratory (Rise Bibliotek), Forsøgsanlæg Rise), DK-4000 Roskilde, Denmark Telephone: (03) 37 12 12, ext. 2262. Telex: 43116</p>	<p>Group's own registration number(s)</p> <p>Copies to</p>